

INDUSTRIAL VIBRATORS

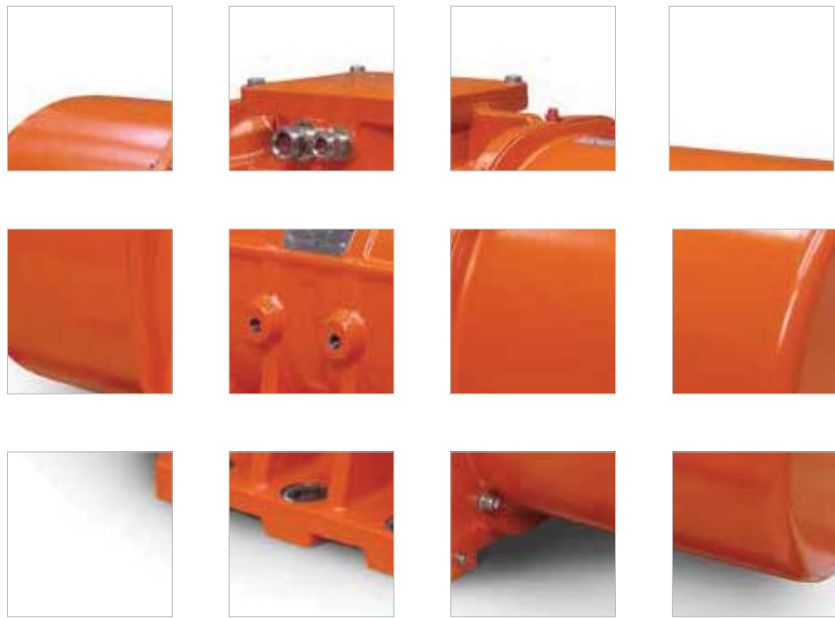

THE WORLDWIDE LEADER IN VIBRATION TECHNOLOGY



OLI



Jamieson Equipment Company
www.jamiesonequipment.com
toll free 800.875.0280





Intro

Company profile	4
Technical features	6
Standard specifications	7
The OLI vibrator range	8
Certifications	9
How to choose a motovibrator	10

MVE standard range

2 poles	12
4 poles	14
6 poles	16
8 poles	18
2 poles single phase	20
MICRO	22
MVE DC Direct Current	24

MVE-E increased safety

2 poles	26
4 poles	28
6 poles	30
8 poles	32

MVE-D explosion-proof

2 and 4 poles	34
6 and 8 poles	36

MVE hi-stroke milling

8 and 10 poles	38
----------------	----

Installation

Mounting	40
How to change vibration intensity	42



Worldwide leader in vibration technology

OLI is the world's top selling manufacturer of Electric and Pneumatic Vibrators. A high level of customer service is guaranteed through 19 OLI Trading Subsidiaries, 36 local warehouses and 5 manufacturing plants worldwide.

OUR 3 DIVISIONS

PROVIDE CUSTOMERS WITH OPTIMAL SOLUTIONS FOR ALL REQUIREMENTS

INDUSTRIAL VIBRATORS



Electric motovibrators for vibrating equipments

FLOW AIDS



Comprehensive range of electric and pneumatic vibrators to solve any problem of flowability

CONCRETE CONSOLIDATION



Internal concrete vibrators and converters for reliable and efficient concrete compaction



Jamieson Equipment Company
www.jamiesonequipment.com
toll free 800.875.0280



Originally specialising in immersion vibrators for concrete consolidation, OLI is now the worldwide leader in vibration technology, with a **complete range of electric and pneumatic internal and external vibrators.**

By supplying **competitive, high quality products for wide-ranging applications,** OLI combines **performance** and **reliability** by adapting to the ever-changing market. A strong believer in innovation, OLI is constantly striving to be ahead of the opposition.

As a global player in industrial vibration technology, the key focus of OLI's business strategy is **rapid stock delivery, any time, anywhere in the world.**

Excellent customer service is of pivotal importance: the company guarantees **quick order processing** and customers worldwide can enjoy access to the same high quality product and services.

OLI has access to credible expertise when it comes to finding suitable solutions to customers' requests. A team of engineers specialised in designing efficient, reliable and safe solutions backed by a **globally certified management.**

OLI provide their customers with state-of-the-art equipment and the blueprint for the next generation of products is already in progress.



TECHNICAL FEATURES

QUALITY



- World class materials
- Class F insulation
- Durable sealing
- Premium bearings
- Strong body design - FEM designed
- Vacuum insulation
- FMEA analysis
- 3D quality check

EFFICIENCY

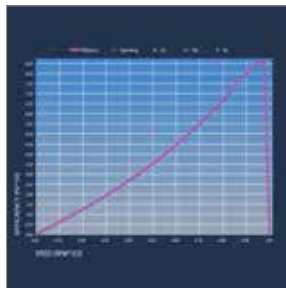

- Optimised power/weight ratio
- S1 continuous duty service
- Optimized electric design

RELIABILITY



- PTC thermistor 130 °C
- Specific grease retaining device
- Tropicalised standard
- IP66 protection
- Class F insulation

FLEXIBILITY



- Easy mass adjustment
- Various voltages and frequencies available
- Easy access to the terminal box
- Multiple eye-bolts





Standard specifications

	RANGE			
Specification	Standard	Increased Safety	Explosion-Proof	Hi-stroke Milling
Power supply	Three-phase from 12V to 690V, 50Hz or 60Hz; Single phase 110V 60Hz and 220V 50Hz. Three-phase motors are designed for inverter application	Three-phase from 230V to 460V, 50Hz or 60Hz	Three-phase from 230V to 690V, 50Hz or 60Hz. All motors are designed for inverter application from 20Hz to base frequency	
Time rating	Continuous duty (S1)			
Protection structure	Mechanical protection IP66 according to EN 60529			
Bearings	Ball bearings from size MICRO to 50, roller bearings from size 60 to 110	Ball bearings from size 10 to 50, roller bearings from size 60 to 90	Roller bearings	
Coating colour	Polyester powder coating. Standard colour RAL 2009			
Installation and operating environment	For indoor and outdoor use			
	Ambient temperature: -20 °C to +40 °C. Up to +55 °C available on request	Ambient temperature: -20 °C to +40 °C	Ambient temperature: -20 °C to +40 °C. Up to +55 °C available on request	Ambient temperature: -20 °C to +40 °C
Standards supported	Conformity with European Directive Low voltage 2006/95/EC EMC 2004/108/EC Machine directive 2006/42/EC ATEX 94/9/EC			
Mass covers	Aluminium. Steel for motors from size 60 to size 90. AISI 304 Stainless Steel for direct current motovibrators	Aluminium. Steel for motors from size 60 to size 90	AISI 304 Stainless Steel	Steel
Windings	2, 4, 6 and 8 poles three-phase asynchronous motor from size 10 to 110; 2 poles single phase from size 10 to 30	2, 4, 6 and 8 poles three-phase asynchronous motor		8 and 10 poles three-phase asynchronous motor
	Class F insulating materials (155 °C). Vacuum impregnated windings; PTC thermistor 130 °C standard from size 60			
Flanges	Grey cast iron up to size 80, ductile cast iron from size 100			
Frame	Aluminium up to size 50, ductile cast iron from size 60			
Shaft	Steel alloy highly resistant			
Eccentric masses	Completely adjustable			



The OLI Vibrator Range

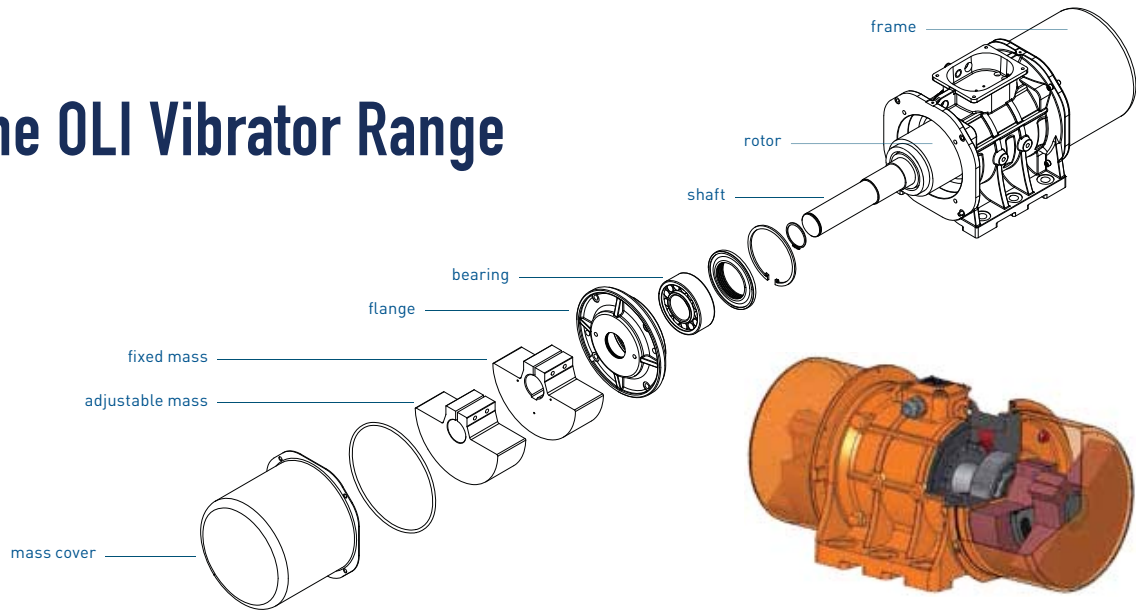

Providing centrifugal force up to 26,000 kgs and with multiple voltage options OLI's range of electric motovibrators covers several fields of application in every country as well as many different industrial sectors: from food to mining, from foundry to recycling and more.

OLI's electric motovibrators are designed and manufactured using the latest technologies and premium quality materials and components.

Motor bodies, bearing flanges and shafts are FMEA designed and manufactured using first grade Aluminium alloy, cast iron and steel alloy to withstand heavy duty applications and

guarantee safe operation in any condition.

Vacuum impregnated windings and class F insulating materials enhance reliability and durability.

Top quality bearings and an efficient grease retaining system assure long lasting performance and low noise generation. Adjustable eccentric masses allow easy fine tuning of the Max centrifugal force provided by the motor.

Several certifications for use in hazardous environments are available in the OLI range to match the most demanding specification worldwide.

Range	Model		Poles	Vibrating Force (kg)	Voltage Class (V)	Speed at 50Hz/ 60Hz (rpm)	Input Power (kW)
Standard	2-8 poles	MVE	2	66 - 9,375	Three-phase from 220V to 690V, 50Hz or 60Hz.	3,000/3,600	0.04 - 17
			4	25 - 15,153		1,500/1800	
			6	53 - 25,532		1,000/1,200	
			8	105 - 26,489		750/900	
	Micro	MICRO	2	4 - 65	Three-phase from 230V to 460V, 50Hz or 60Hz. Single-phase 115V 60Hz and 230V 50Hz.	3,000/3,600	0.03 - 0.07
Single-phase	MVE-M	2	66 - 320	115V 60Hz and 230V 50Hz.	3,000/3,600	0.08 - 0.28	
Direct Current	MVE-DC	-	50 - 200	12V and 24V.	3,000	0.08 - 0.16	
Increased Safety	2-8 poles	MVE-E	2	187 - 4,052	Three-phase from 220V to 690V, 50Hz or 60Hz.	3,000/3,600	0.12 - 13
			4	194 - 15,153		1,500/1,800	
			6	51 - 13,009		1,000/1,200	
			8	105 - 9,952		750/900	
Explosion-proof	2-8 poles	MVE-D	2	794 - 4,052	Three-phase from 220V to 690V, 50Hz or 60Hz.	3,000/3,600	0.35 - 3.9
			4	714 - 5,495		1,500/1,800	
			6	513 - 4,697		1,000/1,200	
			8	179 - 3,792		750/900	
Hi-stroke Milling	8-10 poles	MVE-MILLING	8	1203 - 1,480		750/900	0.65 - 0.78
			10	770 - 1,364		600/720	

Certifications

Range	Certifications	Category	Type of protection	Temperature rating	Directive
Standard Range		Ex II3D Class II Div.2 Groups F, G NEMA4	Enclosure Ex tD A22 Tx IP66	Micro and up to size 50 = T100 °C From size 60 up = T135 °C	Conformity with European Directive Low voltage 2006/95/EC EMC 2004/108/EC Machine Directive 2006/42/EC ATEX 94/9/EC
Standard Range  [zone 21]		Ex II2D Class II Div.2 Groups F, G NEMA4	Enclosure Ex tb A21 IIIC Tx Db IP66	Micro and up to size 50 = T100 °C From size 60 up = T110 °C	UL 1836, UL 1004-1 CSAC22,2 NO 25, 100, 145
Increased Safety		Ex II2GD	Increased safety Ex e II T3 Ex tD A21 T150 °C IP66	T3 T150 °C	Conformity with European Directive Low voltage 2006/95/EC EMC 2004/108/EC Machine Directive 2006/42/EC ATEX 94/9/EC
Explosion-proof		Ex II2GD Class I Div.1 Groups C, D Class II Div.1 Groups E, F, G IP66	Flame-proof Ex d IIB T4 Ex tD A21 IP66 T135 °C Ex db IIB T4, Ex tb IIIC T135 °C	T4 T135 °C	Conformity with European Directive Low voltage 2006/95/EC EMC 2004/108/EC Machine Directive 2006/42/EC ATEX 94/9/EC
Explosion-proof D5		Ex II2G Class I Div.1 Groups C, D IP66	Flame-proof Ex d IIB T3 IP66 Ex db IIB T3	T3	UL 1836, UL 1004-1, UL 674 CSAC22,2 NO 25, 100, 145
Hi-stroke Milling		Ex II3D	Enclosure Ex tD A22 Tx IP66	T135 °C	Conformity with European Directive Low voltage 2006/95/EC EMC 2004/108/EC Machine Directive 2006/42/EC ATEX 94/9/EC



How to choose a motovibrator

1.

Choose rpm and the amplitude "e" (0 - peak) suitable for your application:

Circular vibration

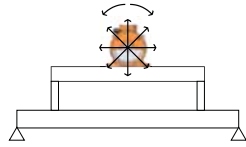

Linear vibration

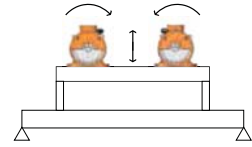

Application processes	Vibration		Revolutions Per Minute					
			50Hz	750	1000	1500	3000	6000
	Circular	Linear	60Hz	900	1200	1800	3600	-
Conveying		✓			✓	✓		
Separation / Screening / Sizing		✓		✓	✓	✓		
Positioning / Feeding		✓		✓	✓	✓		
Filter cleaning	✓						✓	
Silo/hopper emptying	✓						✓	
Fluid beds		✓		✓	✓			
Bin activators	✓					✓	✓	
Compacting		✓					✓	✓
Concrete consolidation	✓						✓	✓

rpm	e (mm)	
	Min.	Max.
3,600	0.3	0.6
3,000	0.3	0.8
1,800	1.2	2.2
1,500	1.4	2.6
1,200	2.5	4.0
1,000	3.0	5.2
9,00	3.5	5.5
750	3.5	6.0

2.

Choose an MVE from the tables of the following pages and use its Wm into this formula:

$$e = 5 \times \frac{n \times Wm}{n \times M_{mot} + M_{vm}}$$

e = amplitude of vibration 0-peak (mm)

n = number of vibrating motors

Wm = working moment (kgcm)

M_{mot} = motor weight (kg)

M_{vm} = vibrating machine weight (without material and motors)

3.

Check the obtained value “e”:

- If it is similar to the required one (step 1) → the MVE model is correct.
- If it is not similar to the required one (step 1) → repeat the process (step 2) with a different MVE model.

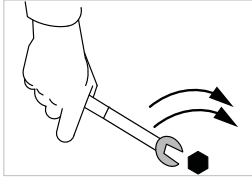

For tips on installation see section page 40



Important

Several voltages are available to match local electric specifications worldwide both at 50Hz and 60Hz.

All OLI motors can be operated with double voltage by simply changing the connections inside the terminal box from Star to Delta or vice-versa.

Three-phase MVEs with double rated voltage:

- ∧ (Star) High Voltage - Factory preset
- Δ (Delta) Low Voltage

MVEs with “(Delta)”:

- Δ (Delta) Low Voltage - Factory preset
- ∧ (Star) High Voltage

For details about “Star” and “Delta” connections see page 41.

VOLTAGE Delta / Star	Frequency (Hz)	Standard
200-230 / 345-400	50 / 60	✓
220 (Single-phase)	60	
220-240 / 380-415	50	✓
230 / 460 *	60	✓
230 (Single-phase)	50	
330 / 575 *	60	✓
220-277 / 380-480	60	✓
500-525 (Delta)	50	✓
290-300 / 500-525	50	✓
380-480 (Delta)	60	✓
575 (Delta) *	60	✓
380-415 (Delta)	50	✓
460 (Delta) *	60	✓
115 (Three-phase)	50 / 60	
115 (Single-phase)	60	✓
115 (Single-phase)	50	✓
48 / 80	50 / 60	

* Voltage Tolerance: ± 10%



» I13 D Ex tD A22 Tx IP66
 » TÜV NORD Statement Conformity Number TÜV 05 ATEX 2768X
 » Equipment and protective system intended for use in potentially explosive atmospheres (Zone 22) - Directive 94/9/EC
 » Compliance with Essential Health and Safety Requirements
 » IEC 60079-10-2



MVE STANDARD RANGE



2 POLES - 3000/3600 rpm

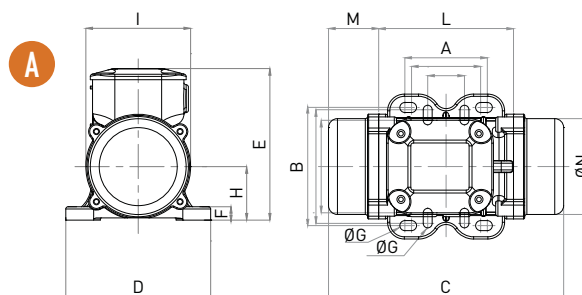

* Image referred to size 50

Wm (kgcm)		Model		Centrifugal Force (kg)		Weight (kg)		ELECTRICAL SPECIFICATIONS						CERTIFICATE		
50Hz	60Hz	50Hz	60Hz	50Hz	60Hz	50Hz	60Hz	Input Power (kW)		Nominal Current A max. (Y)		Ia / In		Cable Gland	Class II Div.2	Ex I13D
								50Hz	60Hz	50Hz (400V)	60Hz (460V)	50Hz	60Hz	Metric	Temp. Class	Temp. Class
1	1	MVE 60/3	MVE 60/36	66	71	4		0.1	0.1	0.2	0.2	3.0	3.0	M16	T4	100 °C
2	1	MVE 100/3	MVE 100/36	98	95	5		0.1	0.1	0.2	0.2	3.0	3.0	M16	T4	100 °C
4	3	MVE 200/3	MVE 200/36	187	189	7		0.2	0.2	0.3	0.3	3.3	3.3	M20	T4	100 °C
4	3	MVE 202/3	MVE 202/36	187	189	7		0.2	0.2	0.3	0.3	3.3	3.3	M20	T4	100 °C
6	4	MVE 300/3	MVE 300/36	321	323	10		0.3	0.3	0.5	0.4	3.6	3.5	M20	T4	100 °C
8	6	MVE 400/3	MVE 400/36	407	411	10		0.3	0.4	0.6	0.6	3.5	3.5	M20	T4	100 °C
10	7	MVE 500/3	MVE 500/36	530	534	16		0.5	0.6	1.0	1.0	4.0	4.2	M20	T4	100 °C
15	11	MVE 700/3	MVE 700/36	758	765	16		0.7	0.7	1.2	1.2	4.3	5.0	M20	T4	100 °C
16	11	MVE 800/3	MVE 800/36	794	800	21		0.7	0.9	1.4	1.5	3.8	3.8	M20	T4	100 °C
20	16	MVE 1200/3	MVE 1200/36	1,005	1,013	22		0.9	1.1	1.8	1.9	4.4	4.5	M20	T4	100 °C
27	19	MVE 1300/3	MVE 1300/36	1,355	1,365	22		1.3	1.4	2.4	2.2	5.2	5.0	M20	T4	100 °C
27	19	MVE 1301/3	MVE 1301/36	1,355	1,365	34		1.3	1.4	2.4	2.2	5.2	5.0	M20	T4	100 °C
22	22	MVE 1310/3	MVE 1310/36	1,123	1,616	34		1.3	1.4	2.4	2.2	5.2	5.0	M20	T4	100 °C
31	22	MVE 1600/3	MVE 1600/36	1,601	1,608	52	51	1.6	1.6	2.9	2.6	5.9	6.2	M25	T4	135 °C
37	28	MVE 2000/3	MVE 2000/36	2,027	1,997	53	52	2.0	2.1	3.7	3.4	6.5	6.4	M25	T4	135 °C
46	32	MVE 2300/3	MVE 2300/36	2,302	2,306	54	52	2.4	2.4	4.4	3.9	6.0	6.3	M25	T4	135 °C
68	44	MVE 3200/3	MVE 3200/36	3,252	3,176	103	101	2.9	2.9	5.3	4.6	8.3	8.2	M32	T4	135 °C
79	56	MVE 4000/3	MVE 4000/36	4,033	4,052	107	104	2.9	2.9	5.3	4.6	8.5	9.7	M32	T4	135 °C
103	70	MVE 5000/3	MVE 5000/36	5,009	5,048	111	106	4.0	4.0	7.2	6.3	8.5	9.8	M32	T4	135 °C
								A max. (Δ)								
129	90	MVE 6500/3	MVE 6500/36	6,510	6,552	228	230	5.5	5.0	9.5	8.0	8.5	8.8	M32	T4	135 °C
180	129	MVE 9000/3	MVE 9000/36	9,025	9,375	240	235	10.0	9.0	14.0	18.0	8.4	8.6	M32	T4	135 °C





» Declaration of conformity "type B" according to:
2006/95/EC - 2004/108/EC - 2006/42/EC - EN 60034-1



» Class II Div.2 Group F, G - T4 - NEMA 4
» Conform to UL 1836, UL1004-1 Cert. CSA C22.2 N. 25, 100, 145
» Intertek ETL - SEMCO File Number 3177001

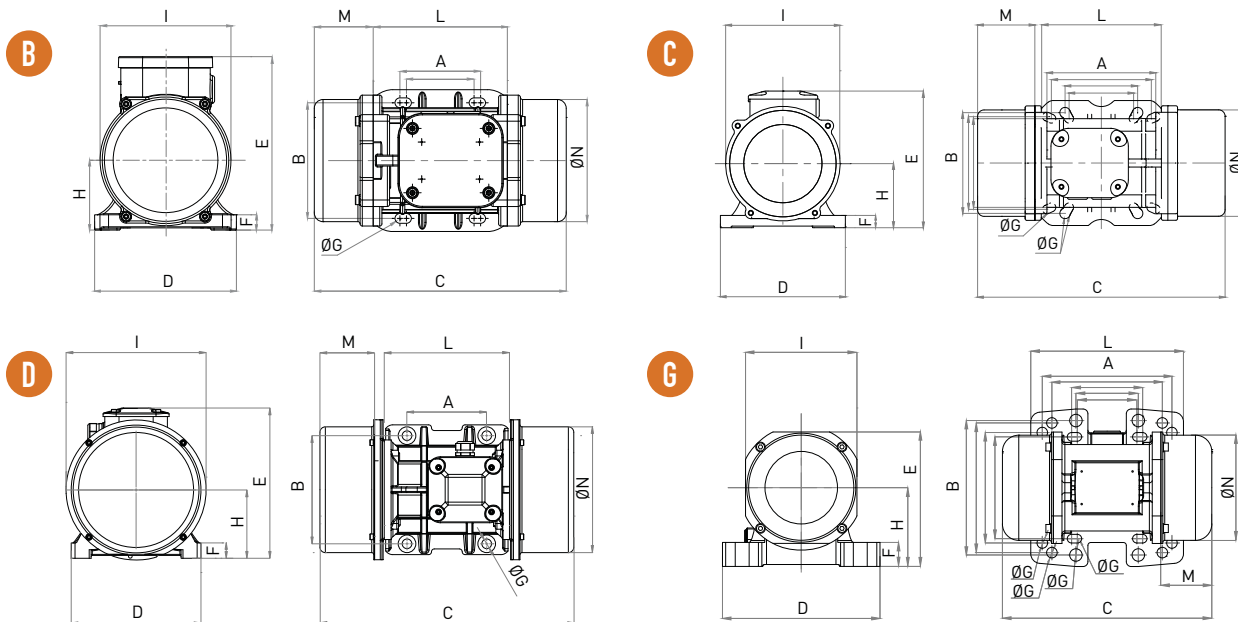

Model		Drawing	Size	DIMENSIONAL SPECIFICATIONS (mm)														
50Hz	60Hz			C		M		A	B	ØG	Holes	D	E	F	H	I	L	N
				50Hz	60Hz	50Hz	60Hz											
								Multiple Footprint		N°								
MVE 60/3	MVE 60/36	A	10	211	45	Multiple Footprint		62-74 106 9		4	130	136	12	48	94	121	85	
MVE 100/3	MVE 100/36	A	10	211	45	Multiple Footprint		33 83-102 7		4	130	136	12	48	94	121	85	
MVE 200/3	MVE 200/36	B	20	231	54	62-74	106	9	4	131	159	15	64	121	123	112		
MVE 202/3	MVE 202/36	G	23	218	53	Multiple Footprint		62-74 106 9		4	164	140	25	82	116	159	110	
						65 140 13												
						115 135 11												
						135 115 11												
MVE 300/3	MVE 300/36	C	30	253	45	Multiple Footprint		80 110 11		4	154	175	15	79	142	163	131	
						90 125 13												
MVE 400/3	MVE 400/36	C	30	273	55	Multiple Footprint		124 110 11		4	154	175	15	79	142	163	131	
						135 115 11												
MVE 500/3	MVE 500/36	D	40	334	78	105	140	13	4	168	196	22	92	169	178	158		
MVE 700/3	MVE 700/36	D	40	334	78	105	140	13	4	168	196	22	92	169	178	158		
MVE 800/3	MVE 800/36	D	50	321	58	120	170	17	4	208	210	22	94	180	205	170		
MVE 1200/3	MVE 1200/36	D	50	321	58	120	170	17	4	208	210	22	94	180	205	170		
MVE 1300/3	MVE 1300/36	D	50	321	58	120	170	17	4	208	210	22	94	180	205	170		
MVE 1301/3	MVE 1301/36	D	53	321	58	100	180	17	4	236	210	26	98	180	205	170		
MVE 1310/3	MVE 1310/36	D	55	321	58	100	200	17	4	236	210	26	98	180	205	170		
MVE 1600/3	MVE 1600/36	D	60	418	83	140	190	17	4	229	262	30	120	247	220	222		
MVE 2000/3	MVE 2000/36	D	60	418	83	140	190	17	4	229	262	30	120	247	220	222		
MVE 2300/3	MVE 2300/36	D	60	418	83	140	190	17	4	229	262	30	120	247	220	222		
MVE 3200/3	MVE 3200/36	D	75	538	115	155	255	25	4	302	318	35	147	295	273	264		
MVE 4000/3	MVE 4000/36	D	75	538	115	155	255	25	4	302	318	35	147	295	273	264		
MVE 5000/3	MVE 5000/36	D	75	588	538	140	115	155	255	25	4	302	318	35	147	295	273	264
MVE 6500/3	MVE 6500/36	D	85	605	120	200	320	28	4	378	411	49	199	424	325	378		
MVE 9000/3	MVE 9000/36	D	85	605	120	200	320	28	4	378	411	49	199	424	325	378		

NOTE: Dimensions with coarse degree of accuracy related to UNI 22768/1

This information is provided without warranty, representation, inducement or licence of any kind. It is accurate to the best OLI knowledge or is obtained from sources believed to be accurate. OLI therefore assumes no legal responsibility.

STANDARD

EXPLOSION-PROOF

HI-STROKE MILLING





» I13 D Ex tD A22 Tx IP66
 » TÜV NORD Statement Conformity Number TÜV 05 ATEX 2768X
 » Equipment and protective system intended for use in potentially explosive atmospheres (Zone 22) - Directive 94/9/EC
 » Compliance with Essential Health and Safety Requirements
 » IEC 60079-10-2



MVE STANDARD RANGE



4 POLES - 1500/1800 rpm

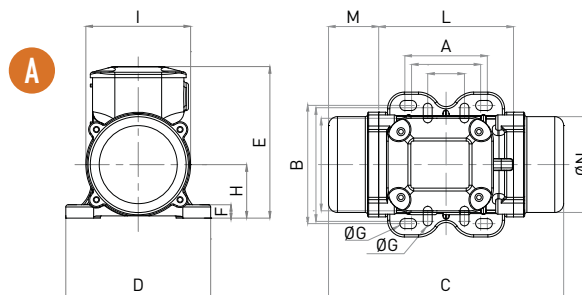

* Image referred to size 90

Wm (kgcm)		Model		Centrifugal Force (kg)		Weight (kg)		ELECTRICAL SPECIFICATIONS						CERTIFICATE		
50Hz	60Hz	50Hz	60Hz	50Hz	60Hz	50Hz	60Hz	Input Power (kW)		Nominal Current A max. (Y)		Ia / In		Cable Gland	Class II Div.2	Ex I13D
50Hz	60Hz	50Hz	60Hz	50Hz	60Hz	50Hz	60Hz	50Hz	60Hz	50Hz (400V)	60Hz (460V)	50Hz	60Hz	Metric	Temp. Class	Temp. Class
2	2	MVE 40/15	MVE 40/18	25	36	5		0.04	0.05	0.3	0.3	2.0	2.0	M16	T4	100 °C
6	4	MVE 90/15	MVE 90/18	75	76	7		0.1	0.1	0.3	0.3	3.5	3.8	M20	T4	100 °C
15	11	MVE 200/15	MVE 200/18	194	196	12		0.2	0.2	0.5	0.5	2.0	2.0	M20	T4	100 °C
33	23	MVE 400/15	MVE 400/18	420	423	19		0.3	0.3	0.8	0.9	2.5	2.5	M20	T4	100 °C
40	28	MVE 500/15	MVE 500/18	504	508	21		0.3	0.4	1.1	1.1	2.8	2.7	M20	T4	100 °C
27	19	MVE 300/15	MVE 300/18	334	336	22		0.6	0.7	1.3	1.4	3.0	3.2	M20	T4	100 °C
57	39	MVE 700/15	MVE 700/18	714	712	27		0.6	0.7	1.3	1.4	3.0	3.2	M20	T4	100 °C
89	62	MVE 1100/15	MVE 1100/18	1.114	1.122	36	28	0.6	0.8	1.5	1.7	3.8	3.8	M20	T4	100 °C
109	77	MVE 1400/15	MVE 1400/18	1.364	1.388	60	58	0.9	1.1	1.7	1.8	4.0	4.0	M25	T4	135 °C
137	92	MVE 1700/15	MVE 1700/18	1.725	1.664	62	59	1.1	1.3	2.2	2.1	4.7	4.5	M25	T4	135 °C
188	137	MVE 2400/15	MVE 2400/18	2.358	2.485	68	62	1.6	1.9	3.0	3.2	4.9	4.9	M25	T4	135 °C
203	136	MVE 2500/15	MVE 2500/18	2.557	2.454	90	84	1.8	2.0	3.4	3.4	6.0	6.1	M25	T4	135 °C
249	170	MVE 3000/15	MVE 3000/18	3.124	3.071	97	87	1.9	2.3	3.7	3.8	6.5	6.6	M25	T4	135 °C
307	205	MVE 3800/15	MVE 3800/18	3.853	3.704	130	118	2.2	2.6	4.1	4.1	6.8	6.8	M32	T4	135 °C
343	241	MVE 4300/15	MVE 4300/18	4.312	4.359	134	124	2.5	3.0	5.7	5.8	7.0	7.2	M32	T4	135 °C
437	304	MVE 5500/15	MVE 5500/18	5.495	5.495	192	190	3.6	3.4	6.5	6.6	7.1	7.0	M32	T4	135 °C
								A max. (Δ)								
577	397	MVE 7200/15	MVE 7200/18	7.246	7.188	253	247	5.0	6.0	9.6	9.4	6.8	6.9	M32	T4	135 °C
718	499	MVE 9000/15	MVE 9000/18	9.020	9.023	269	258	7.5	8.5	12.0	12.0	7.0	7.0	M32	T4	135 °C
800	588	MVE 10000/15	MVE 10000/18	1.0052	1.0643	312	297	7.8	9.4	13.0	13.0	6.5	6.4	M32	T4	135 °C
939	655	MVE 11500/15	MVE 11500/18	1.1779	1.1853	445	422	9.0	10.0	15.5	15.5	7.0	7.0	M32	-	135 °C
1.142	838	MVE 14500/15	MVE 14500/18	1.4352	1.5153	460	442	11.0	13.0	18.5	18.5	8.0	8.0	M32	-	135 °C



UP TO SIZE 60 (NOT INCLUDED)
 60Hz masses = 50Hz masses adjusted at 70%
 Except for model MVE 1100/15 - 1100/18



ABOVE SIZE 60 (INCLUDED)
 Specific masses for 60Hz

To convert kg into Newton: $N = 9.81 \cdot kg$





» Declaration of conformity "type B" according to:
2006/95/EC - 2004/108/EC - 2006/42/EC - EN 60034-1



» Class II Div.2 Group F, G - T4 - NEMA 4
» Conform to UL 1836, UL1004-1 Cert. CSA C22.2 N. 25, 100, 145
» Intertek ETL - SEMCO File Number 3177001

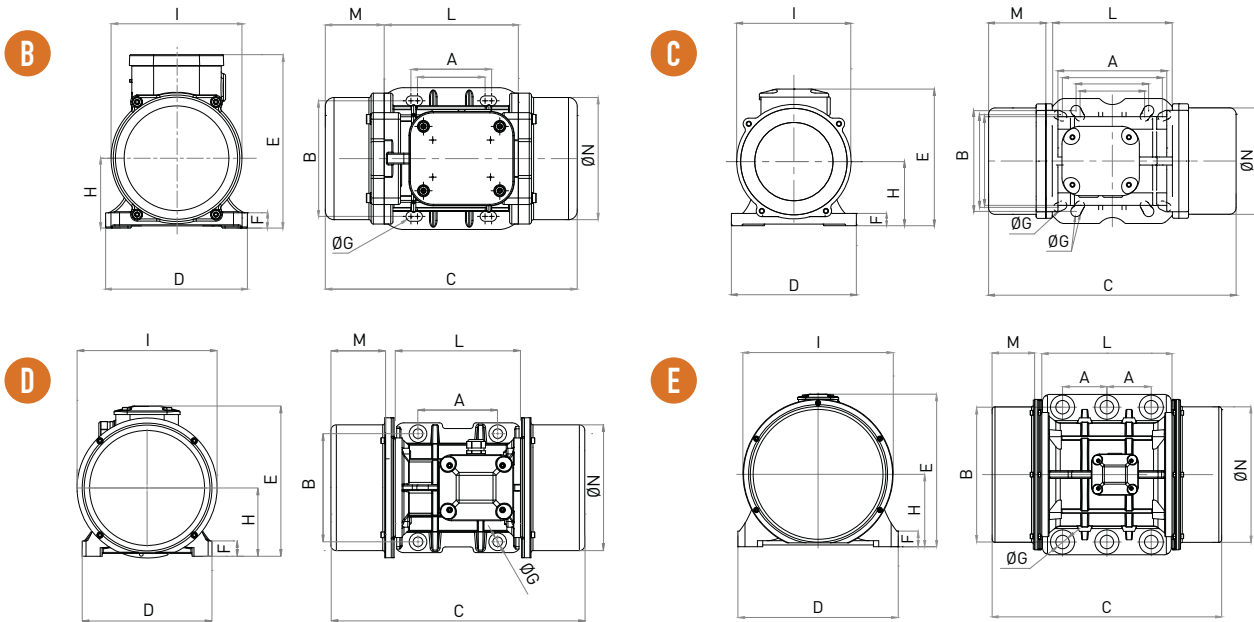

STANDARD
EXPLOSION-PROOF
INCREASED SAFETY
HI-STROKE MILLING

Model		Drawing	Size	DIMENSIONAL SPECIFICATIONS (mm)														
50Hz	60Hz			C	M		A	B	ØG	Holes	D	E	F	H	I	L	N	
				50Hz	60Hz	50Hz	60Hz											
MVE 40/15	MVE 40/18	A	10	211	45	Multiple Footprint 62-74 106 9 33 83-102 7			4	130	136	12	48	94	121	85		
MVE 90/15	MVE 90/18	B	20	231	54	62-74	106	9	4	131	159	15	64	121	123	112		
MVE 200/15	MVE 200/18	C	30	273	55	Multiple Footprint 80 110 11 90 125 13 124 110 11 135 115 11			4	154	175	15	79	142	163	131		
MVE 400/15	MVE 400/18	D	40	334	78	105	140	13	4	168	196	22	92	169	178	158		
MVE 500/15	MVE 500/18	D	40	334	78	105	140	13	4	168	196	22	92	169	178	158		
MVE 300/15	MVE 300/18	D	50	321	58	120	170	17	4	208	210	22	94	180	205	170		
MVE 700/15	MVE 700/18	D	50	391	93	120	170	17	4	208	210	22	94	180	205	170		
MVE 1100/15	MVE 1100/18	D	50	451	391	123	93	120	170	17	4	208	210	22	94	180	205	170
MVE 1400/15	MVE 1400/18	D	60	446	96	140	190	17	4	229	262	30	120	247	220	222		
MVE 1700/15	MVE 1700/18	D	60	446	96	140	190	17	4	229	262	30	120	247	220	222		
MVE 2400/15	MVE 2400/18	D	60	510	446	129	96	140	190	17	4	229	262	30	120	247	220	222
MVE 2500/15	MVE 2500/18	D	70	522	486	123	105	155	225	22	4	272	295	40	140	267	250	235
MVE 3000/15	MVE 3000/18	D	70	522	486	123	105	155	225	22	4	272	295	40	140	267	250	235
MVE 3800/15	MVE 3800/18	D	75	588	538	140	115	155	255	23.5	4	302	318	35	147	295	273	264
MVE 4300/15	MVE 4300/18	D	75	588	140	155	255	23.5	4	302	318	35	147	295	273	264		
MVE 5500/15	MVE 5500/18	D	80	603	130	180	280	26	4	332	360	37	167	345	304	310		
MVE 7200/15	MVE 7200/18	D	85	608	120	200	320	28	4	378	411	49	200	424	325	378		
MVE 9000/15	MVE 9000/18	D	85	608	120	200	320	28	4	378	411	49	200	424	325	378		
MVE 10000/15	MVE 10000/18	E	90	726	646	160	120	125	380	39	6	452	430	44	204	422	367	378
MVE 11500/15	MVE 11500/18	E	100	890	210	140	440	45	6	530	484	37	232	446	470	424		
MVE 14500/15	MVE 14500/18	E	100	890	210	140	440	45	6	530	484	37	232	446	470	424		

NOTE: Dimensions with coarse degree of accuracy related to UNI 22768/1

This information is provided without warranty, representation, inducement or licence of any kind. It is accurate to the best OLI knowledge or is obtained from sources believed to be accurate. OLI therefore assumes no legal responsibility.





- » I13 D Ex tD A22 Tx IP66
- » TÜV NORD Statement Conformity Number TÜV 05 ATEX 2768X
- » Equipment and protective system intended for use in potentially explosive atmospheres (Zone 22) - Directive 94/9/EC
- » Compliance with Essential Health and Safety Requirements
- » IEC 60079-10-2



MVE STANDARD RANGE



6 POLES - 1000/1200 rpm



*1



*2

*1 Image referred to size 105

*2 Image referred to size 30

Wm (kgcm)		Model		Centrifugal Force (kg)		Weight (kg)		ELECTRICAL SPECIFICATIONS								CERTIFICATE	
50Hz	60Hz	50Hz	60Hz	50Hz	60Hz	50Hz	60Hz	Input Power (kW)		Nominal Current A max. (Y)		Ia / In		Cable Gland	Class II Div.2	Ex I13D	
50Hz	60Hz	50Hz	60Hz	50Hz	60Hz	50Hz	60Hz	50Hz	60Hz	50Hz (400V)	60Hz (460V)	50Hz	60Hz	Metric	Temp. Class	Temp. Class	
9	7	MVE 50/1	MVE 50/12	53	53	10		0.1	0.1	0.4	0.5	2.0	2.0	M20	T4	100 °C	
19	13	MVE 100/1	MVE 100/12	105	106	12		0.1	0.1	0.4	0.5	2.0	2.0	M20	T4	100 °C	
33	23	MVE 200/1	MVE 200/12	187	188	20		0.2	0.2	0.5	0.5	2.0	2.0	M20	T4	100 °C	
57	40	MVE 300/1	MVE 300/12	318	320	27		0.3	0.4	0.7	0.6	2.5	2.5	M20	T4	100 °C	
92	64	MVE 500/1	MVE 500/12	513	517	34		0.3	0.4	1.2	1.1	2.0	2.7	M20	T4	100 °C	
92	92	MVE 510/1	MVE 510/12	513	517	34		0.3	0.4	1.2	1.1	2.8	2.7	M20	T4	100 °C	
137	109	MVE 800/1	MVE 800/12	767	873	62	59	0.7	0.8	1.4	1.3	3.2	3.1	M25	T4	135 °C	
188	137	MVE 1100/1	MVE 1100/12	1,048	1,104	79	73	0.7	0.8	1.4	1.3	3.2	3.1	M25	T4	135 °C	
285	196	MVE 1500/1	MVE 1500/12	1,590	1,580	84	76	1.1	1.3	2.1	2.0	3.3	3.3	M25	T4	135 °C	
300	203	MVE 1600/1	MVE 1600/12	1,673	1,636	100	89	1.1	1.3	2.8	3.2	3.7	3.6	M25	T4	135 °C	
373	249	MVE 2100/1	MVE 2100/12	2,083	2,000	114	100	1.5	1.8	3.0	3.0	4.3	4.4	M25	T4	135 °C	
467	307	MVE 2600/1	MVE 2600/12	2,610	2,466	147	131	2.0	2.1	3.6	3.4	4.8	4.8	M32	T4	135 °C	
540	380	MVE 3000/1	MVE 3000/12	3,017	3,053	155	138	2.2	2.4	4.5	4.3	5.0	5.0	M32	T4	135 °C	
940	658	MVE 5210/1	MVE 5210/12	5,237	5,290	225	191	3.8	4.0	6.9	6.4	5.5	5.5	M25	T4	135 °C	
680	437	MVE 3800/1	MVE 3800/12	3,799	3,517	216	195	2.5	3.0	4.7	4.9	5.9	6.0	M32	T4	135 °C	
838	584	MVE 4700/1	MVE 4700/12	4,681	4,697	231	212	3.2	3.9	6.5	6.0	5.5	5.7	M32	T4	135 °C	
930	655	MVE 5200/1	MVE 5200/12	5,192	5,263	280	264	3.8	4.0	6.9	6.4	5.5	5.5	M32	T4	135 °C	
1165	824	MVE 6500/1	MVE 6500/12	6,506	6,625	304	281	4.3	5.0	7.8	7.8	6.2	6.0	M32	T4	135 °C	
								A max. (Δ)									
1,436	930	MVE 8000/1	MVE 8000/12	8,018	7,476	325	290	7.1	7.5	12.6	11.6	6.0	6.2	M32	T4	135 °C	
1600	1,165	MVE 9000/1	MVE 9000/12	8,936	9,369	338	308	7.5	8.3	13.2	12.6	6.3	6.2	M32	T4	135 °C	
1,788	1,240	MVE 10000/1	MVE 10000/12	9,986	9,970	386	359	7.6	8.0	13.5	12.7	6.4	6.4	M32	T4	135 °C	
2,330	1,647	MVE 13000/1	MVE 13000/12	13,009	13,246	422	376	10.0	10.0	17.0	16.0	6.2	6.3	M32	T4	135 °C	
2,253	1,550	MVE 12000/1	MVE 12000/12	12,580	12,466	522	476	8.0	9.5	15.0	15.0	5.0	5.5	M32	-	135 °C	
2,634	1,856	MVE 15000/1	MVE 15000/12	14,706	14,923	672	630	10.1	12.0	18.0	18.0	5.8	5.8	M32	-	135 °C	
3,220	2,147	MVE 17500/1	MVE 17500/12	17,980	17,264	744	684	11.9	14.2	21.0	21.0	5.6	5.9	M32	-	135 °C	
3,632	2,525	MVE 19500/1	MVE 19500/12	20,285	20,299	768	728	12.0	14.5	24.0	24.0	5.4	5.6	M32	-	135 °C	
4,067	2,622	MVE 22000/1	MVE 22000/12	22,711	21,079	916	868	13.9	17.0	28.0	28.0	4.8	5.3	M32	-	135 °C	
4,572	3,163	MVE 25000/1	MVE 25000/12	25,532	25,432	994	937	13.9	17.0	28.0	28.0	4.8	5.3	M32	-	135 °C	



UP TO SIZE 60 (NOT INCLUDED)
60Hz masses = 50Hz masses adjusted at 70%



ABOVE SIZE 60 (INCLUDED)
Specific masses for 60Hz

To convert kg into Newton: $N = 9.81 \cdot kg$





» Declaration of conformity "type B" according to:
2006/95/EC - 2004/108/EC - 2006/42/EC - EN 60034-1



» Class II Div.2 Group F, G - T4 - NEMA 4
» Conform to UL 1836, UL1004-1 Cert. CSA C22.2 N. 25, 100, 145
» Intertek ETL - SEMCO File Number 3177001

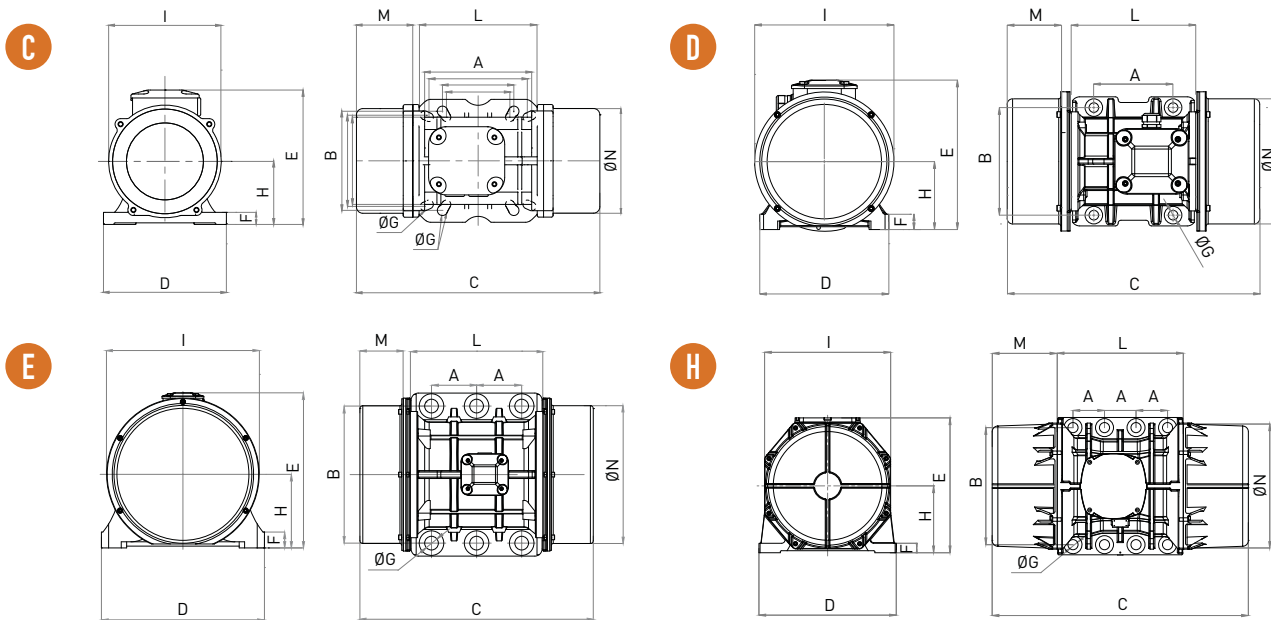

STANDARD
EXPLOSION-PROOF
INCREASED SAFETY
HI-STROKE MILLING

Model		Drawing	Size	DIMENSIONAL SPECIFICATIONS (mm)															
50Hz	60Hz			C		M		A	B	Ø G	Holes	D	E	F	H	I	L	N	
				50Hz	60Hz	50Hz	60Hz				N°								
MVE 50/1	MVE 50/12	C	30	273		55		Multiple Footprint			4	154	175	15	79	142	163	131	
							80	110	11										
							90	125	13										
							124	110	11										
MVE 100/1	MVE 100/12	C	30	303		70		135 115 11			4	154	175	15	79	142	163	131	
							124	110	11										
							135	115	11										
MVE 200/1	MVE 200/12	D	40	334		78		105	140	13	4	168	196	22	92	169	178	158	
MVE 300/1	MVE 300/12	D	50	391		93		120	170	17	4	208	210	22	94	180	205	170	
MVE 500/1	MVE 500/12	D	50	451		123		120	170	17	4	208	210	22	94	180	205	170	
MVE 510/1	MVE 510/12	D	50	451		123		120	170	17	4	208	210	22	94	180	205	170	
MVE 800/1	MVE 800/12	D	60	446		96		140	190	17	4	229	262	30	120	247	220	222	
MVE 1100/1	MVE 1100/12	D	60	510	446	129	96	140	190	17	4	229	262	30	120	247	220	222	
MVE 1500/1	MVE 1500/12	D	60	562	510	154	129	140	190	17	4	229	262	30	120	247	220	222	
MVE 1600/1	MVE 1600/12	D	70	556	522	140	123	155	225	22	4	272	295	40	140	267	250	235	
MVE 2100/1	MVE 2100/12	D	70	616	556	170	140	155	225	22	4	272	295	40	140	267	250	235	
MVE 2600/1	MVE 2600/12	D	75	708	588	200	140	155	255	23.5	4	302	318	35	147	295	273	264	
MVE 3000/1	MVE 3000/12	D	75	708	608	200	150	155	255	23.5	4	302	318	35	147	295	273	264	
MVE 5210/1	MVE 5210/12	E	78	794		242		105	248	22	6	300	335	30	163	305	310	284	
MVE 3800/1	MVE 3800/12	D	80	683	603	170	130	180	280	26	4	332	360	37	167	345	304	310	
MVE 4700/1	MVE 4700/12	D	80	733	683	195	170	180	280	26	4	332	360	37	167	345	304	310	
MVE 5200/1	MVE 5200/12	D	85	688	605	160	120	200	320	28	4	378	411	49	200	424	325	378	
MVE 6500/1	MVE 6500/12	D	85	688		160		200	320	28	4	378	411	49	200	424	325	378	
MVE 8000/1	MVE 8000/12	D	85	788	688	210	160	200	320	28	4	378	411	49	200	424	325	378	
MVE 9000/1	MVE 9000/12	D	85	788	688	210	160	200	320	28	4	378	411	49	200	424	325	378	
MVE 10000/1	MVE 10000/12	E	90	826		210		125	380	39	6	452	430	44	204	422	367	378	
MVE 13000/1	MVE 13000/12	E	90	926	826	260	210	125	380	39	6	452	430	44	204	422	367	378	
MVE 12000/1	MVE 12000/12	E	100	1,020		275		140	440	45	6	530	484	37	232	446	470	424	
MVE 15000/1	MVE 15000/12	H	105	980		210		140	480	45	8	570	542	48	268	510	560	490	
MVE 17500/1	MVE 17500/12	H	105	1,060		250		140	480	45	8	570	542	48	268	510	560	490	
MVE 19500/1	MVE 19500/12	H	105	1,060		250		140	480	45	8	570	542	48	268	510	560	490	
MVE 22000/1	MVE 22000/12	H	110	1,130		285		140	520	45	8	610	594	42	297	560	560	530	
MVE 25000/1	MVE 25000/12	H	110	1,130		285		140	520	45	8	610	594	42	297	560	560	530	





» I13 D Ex tD A22 Tx IP66
 » TÜV NORD Statement Conformity Number TÜV 05 ATEX 2768X
 » Equipment and protective system intended for use in potentially explosive atmospheres (Zone 22) - Directive 94/9/EC
 » Compliance with Essential Health and Safety Requirements
 » IEC 60079-10-2



MVE STANDARD RANGE



8 POLES - 750/900 rpm



*1



*2

*1 Image referred to size 110

*2 Image referred to size 40

Wm (kgcm)		Model		Centrifugal Force (kg)		Weight (kg)		ELECTRICAL SPECIFICATIONS							CERTIFICATE	
								Input Power (kW)		Nominal Current A max. (Y)		Ia / In		Cable Gland	Class II Div.2	Ex I13D
50Hz	60Hz	50Hz	60Hz	50Hz	60Hz	50Hz	60Hz	50Hz	60Hz	50Hz	60Hz	Metric	Temp. Class	Temp. Class		
33		MVE 150/075	MVE 150/090	105	151	21		0.2	0.2	1.1	1.1	1.5	1.5	M20	T4	100 °C
57		MVE 250/075	MVE 250/090	179	257	29		0.3	0.4	1.1	1.1	1.7	1.7	M20	T4	100 °C
84		MVE 400/075	MVE 400/090	264	380	35		0.3	0.4	1.1	1.1	1.9	1.9	M20	T4	100 °C
137		MVE 650/075	MVE 650/090	431	621	65		0.5	0.6	1.2	1.2	2.2	2.2	M25	T4	135 °C
188		MVE 900/075	MVE 900/090	589	849	71		0.6	0.8	1.2	1.3	2.5	2.5	M25	T4	135 °C
300		MVE 1300/075	MVE 1300/090	941	1,355	100		1.2	1.1	2.5	1.8	3.0	3.0	M25	T4	135 °C
467		MVE 2100/075	MVE 2100/090	1,468	2,114	150		1.5	1.8	2.8	2.9	4.2	4.1	M32	T4	135 °C
680		MVE 3100/075	MVE 3100/090	2,137	3,077	212		2.0	2.3	3.8	3.8	4.0	4.0	M32	T4	135 °C
838		MVE 3800/075	MVE 3800/090	2,633	3,792	230		2.5	3.0	6.0	6.0	3.9	4.0	M32	T4	135 °C
930		MVE 4200/075	MVE 4200/090	2,920	4,205	284		2.9	3.4	6.5	6.5	3.8	3.7	M32	T4	135 °C
1,165		MVE 5300/075	MVE 5300/090	3,660	5,270	305		4.0	4.3	8.5	8.0	3.8	4.2	M32	T4	135 °C
1,436		MVE 6500/075	MVE 6500/090	4,510	6,494	324		5.0	5.9	10.0	10.0	3.6	4.0	M32	T4	135 °C
								A max. (Δ)								
2,200		MVE 10000/075	MVE 10000/090	6,911	9,952	422		6.8	7.5	13.5	12.5	3.5	4.2	M32	T4	135 °C
2,835	2,553	MVE 12000/075	MVE 12000/090	8,904	11,546	571	553	7.5	8.0	13.5	13.5	3.8	4.0	M32	-	135 °C
3,713	3,220	MVE 14000/075	MVE 14000/090	11,661	14,563	751	725	9.0	10.6	19.0	19.0	4.5	5.0	M32	-	135 °C
4,401	3,920	MVE 17000/075	MVE 17000/090	13,822	17,729	812	792	9.1	11.0	20.0	20.0	5.3	5.8	M32	-	135 °C
5,857	4,999	MVE 22000/075	MVE 22000/090	18,395	22,610	982	937	13.8	16.5	28.0	28.0	5.6	5.2	M32	-	135 °C
-	5,857	NA	MVE 26000/090	-	26,489	-	982	-	16.5	-	28.0	-	5.2	M32	-	135 °C



UP TO SIZE 90 (INCLUDED)
 60Hz masses = 50Hz masses adjusted at 100%



ABOVE SIZE 90 (NOT INCLUDED)
 Specific masses for 60Hz

To convert kg into Newton: $N = 9.81 \cdot kg$



» Declaration of conformity "type B" according to:
2006/95/EC - 2004/108/EC - 2006/42/EC - EN 60034-1



» Class II Div.2 Group F, G - T4 - NEMA 4
» Conform to UL 1836, UL1004-1 Cert. CSA C22.2 N. 25, 100, 145
» Intertek ETL - SEMCO File Number 3177001

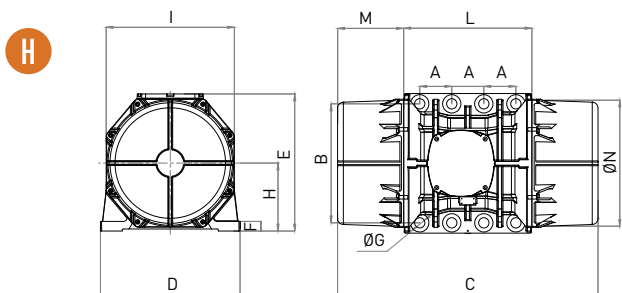
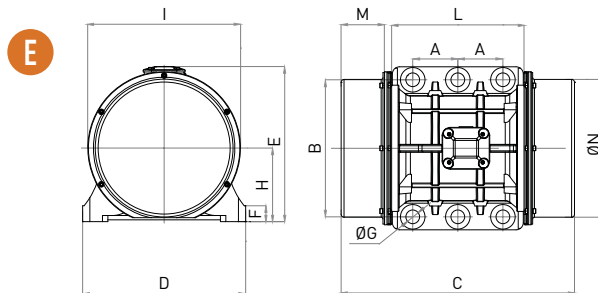
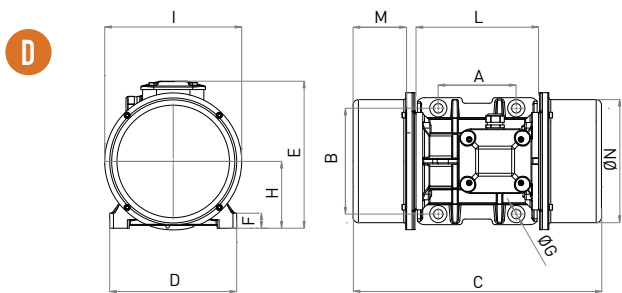

STANDARD

INCREASED SAFETY

EXPLOSION-PROOF

HI-STROKE MILLING

Model		Drawing	Size	DIMENSIONAL SPECIFICATIONS (mm)														
				C		M		A	B	Ø G	Holes	D	E	F	H	I	L	N
				50Hz	60Hz	50Hz	60Hz				N°							
MVE 150/075	MVE 150/090	D	40	334	78	105	140	13	4	168	196	22	92	169	178	158		
MVE 250/075	MVE 250/090	D	50	391	93	120	170	17	4	208	210	22	94	180	205	170		
MVE 400/075	MVE 400/090	D	50	451	123	120	170	17	4	208	210	22	94	180	205	170		
MVE 650/075	MVE 650/090	D	60	446	96	140	190	17	4	229	262	30	120	247	220	222		
MVE 900/075	MVE 900/090	D	60	510	129	140	190	17	4	229	262	30	120	247	220	222		
MVE 1300/075	MVE 1300/090	D	70	556	140	155	225	22	4	272	295	40	140	267	250	235		
MVE 2100/075	MVE 2100/090	D	75	708	200	155	255	23.5	4	302	318	35	147	295	273	264		
MVE 3100/075	MVE 3100/090	D	80	683	170	180	280	26	4	332	360	37	167	345	304	310		
MVE 3800/075	MVE 3800/090	D	80	733	195	180	280	26	4	332	360	37	167	345	304	310		
MVE 4200/075	MVE 4200/090	D	85	688	160	200	320	28	4	378	410	49	199	422	325	378		
MVE 5300/075	MVE 5300/090	D	85	688	160	200	320	28	4	378	410	49	199	422	325	378		
MVE 6500/075	MVE 6500/090	D	85	788	210	200	320	28	4	378	410	49	199	422	325	378		
MVE 10000/075	MVE 10000/090	E	90	926	260	125	380	39	6	452	430	44	204	422	367	378		
MVE 12000/075	MVE 12000/090	E	100	1,020	275	140	440	45	6	530	484	37	232	446	470	424		
MVE 14000/075	MVE 14000/090	H	105	1,060	250	140	480	45	8	570	542	48	268	510	560	490		
MVE 17000/075	MVE 17000/090	H	105	1,120	280	140	480	45	8	570	542	48	268	510	560	490		
MVE 22000/075	MVE 22000/090	H	110	1,130	285	140	520	45	8	610	594	42	297	560	560	530		
NA	MVE 26000/090	H	110	1,130	285	140	520	45	8	610	594	42	297	560	560	530		

NOTE: Dimensions with coarse degree of accuracy related to UNI 22768/1

This information is provided without warranty, representation, inducement or licence of any kind. It is accurate to the best OLI knowledge or is obtained from sources believed to be accurate. OLI therefore assumes no legal responsibility.





- » I13 D Ex tD A22 Tx IP66
- » TÜV NORD Statement Conformity Number TÜV 05 ATEX 2768X
- » Equipment and protective system intended for use in potentially explosive atmospheres (Zone 22) - Directive 94/9/EC
- » Compliance with Essential Health and Safety Requirements
- » IEC 60079-10-2



MVE STANDARD RANGE



2 POLES SINGLE-PHASE - 3000/3600 rpm



*1

*1 Image referred to size 20

Wm (kgcm)		Model		Centrifugal Force (kg)		Weight (kg)		ELECTRICAL SPECIFICATIONS								CERTIFICATE		
								Input Power (kW)		Nominal Current A max		Ia / In		Cable Gland	Capacitor *		Class II Div.2	Ex II3D
50Hz	60Hz	50Hz	60Hz	50Hz	60Hz	50Hz	60Hz	50Hz	60Hz	50Hz (230V)	60Hz (115V)	50Hz	60Hz		Metric	50Hz (230V)	60Hz (115V)	Temp. Class
1	1	MVE 60/3M		66	71	4		0.1	0.1	0.4	3.0	3.0	3.0	M16	3 µF	6,3 µF	T4	100 °C
2	1	MVE 100/3M		98	95	5		0.1	0.1	0.5	3.0	3.0	3.0	M16	4 µF	8 µF	T4	100 °C
4	3	MVE 200/3M		187	189	7		0.2	0.2	1.1	3.3	3.3	3.3	M20	8 µF	16 µF	T4	100 °C
4	3	MVE 202/3M		187	189	7		0.2	0.2	1.1	3.3	3.3	3.3	M20	8 µF	16 µF	T4	100 °C
6	4	MVE 300/3M		321	323	10		0.3	0.3	1.6	3.5	3.6	3.5	M20	12,5 µF	25 µF	T4	100 °C

* NOTE: Capacitor not supplied with vibrator (to be ordered separately)



» Declaration of conformity "type B" according to:
2006/95/EC - 2004/108/EC - 2006/42/EC - EN 60034-1



» Class II Div.2 Group F, G - T4 - NEMA 4
» Conform to UL 1836, UL1004-1 Cert. CSA C22.2 N. 25, 100, 145
» Intertek ETL - SEMCO File Number 3177001

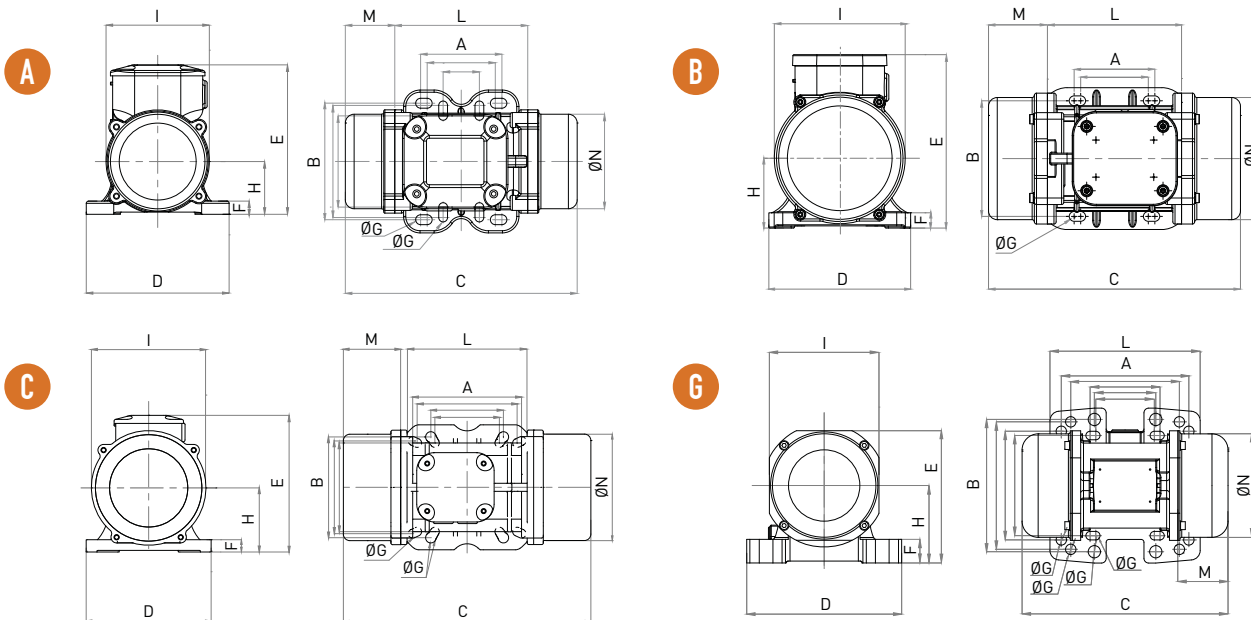

Model		Drawing	Size	DIMENSIONAL SPECIFICATIONS (mm)														
				C		M		A	B	ØG	Holes	D	E	F	H	I	L	N
50Hz	60Hz			50Hz	60Hz	50Hz	60Hz				N°							
MVE 60/3M		A	10	211	60Hz	45		Multiple Footprint		4	130	136	12	48	94	121	85	
								62-74	106	9								
MVE 100/3M		A	10	211	60Hz	45		33	83-102	7	4	130	136	12	48	94	121	85
MVE 200/3M		B	20	231	50Hz	54		62-74	106	9	4	131	159	15	64	121	123	112
MVE 202/3M		G	23	218	50Hz	53		Multiple Footprint			4	164	140	25	82	116	159	110
								62-74	106	9								
								65	140	13								
								115	135	11								
MVE 300/3M		C	30	273	50Hz	55		Multiple Footprint			4	154	175	15	79	142	163	131
								80	110	11								
								90	125	13								
								124	110	11								
								135	115	11								

NOTE: Dimensions with coarse degree of accuracy related to UNI 22768/1

This information is provided without warranty, representation, inducement or licence of any kind. It is accurate to the best OLI knowledge or is obtained from sources believed to be accurate. OLI therefore assumes no legal responsibility.

STANDARD

INCREASED SAFETY

EXPLOSION-PROOF

HI-STROKE MILLING





- » I13 D Ex tD A22 Tx IP66
- » TÜV NORD Statement Conformity Number TÜV 05 ATEX 2768X
- » Equipment and protective system intended for use in potentially explosive atmospheres (Zone 22) - Directive 94/9/EC
- » Compliance with Essential Health and Safety Requirements
- » IEC 60079-10-2



MVE STANDARD RANGE



MICRO - 3000/3600 rpm



THREE-PHASE

Wm (kgcm)		Model		Centrifugal Force (kg)		Weight (kg)		ELECTRICAL SPECIFICATIONS						CERTIFICATE	
								Input Power (kW)		Nominal Current A max			Cable Gland	For 60Hz	For 50Hz
50Hz	60Hz	50Hz	60Hz	50Hz	60Hz	50Hz	60Hz	50Hz	60Hz	50Hz (230V)	50Hz (400V)	60Hz (460V)	Metric	Class II Div.2	II3D
0.4	0.4	MICRO 21		20	29	2		0.04	0.04	0.2	0.1	0.1	M16	Temp. Class	Temp. Class
1	1	MICRO 41		45	65	2		0.1	0.1	0.3	0.2	0.2	M16	T4	100 °C

SINGLE-PHASE

Wm (kgcm)		Model		Centrifugal Force (kg)		Weight (kg)		ELECTRICAL SPECIFICATIONS						CERTIFICATE	
								Input Power (kW)		Nominal Current A max		Cable Gland *	For 60Hz	For 50Hz	
50Hz	60Hz	50Hz	60Hz	50Hz	60Hz	50Hz	60Hz	50Hz (230V)	60Hz (115V)	Metric	Class II Div.2	II3D			
0.1	0.1	MICRO 3 M		4	6	1.6		0.03	0.04	0.3	0.8	M16	Temp. Class	Temp. Class	
0.1	0.1	MICRO 6 M		6	9	1.6		0.03	0.04	0.3	0.8	M16	T4	100 °C	
0.4	0.4	MICRO 21 M		20	29	2		0.04	0.1	0.2	0.8	M16	T4	100 °C	
1	1	MICRO 41 M		45	65	2.4		0.05	0.1	0.2	0.8	M16	T4	100 °C	

NOTE: Capacitor integrated in the cable

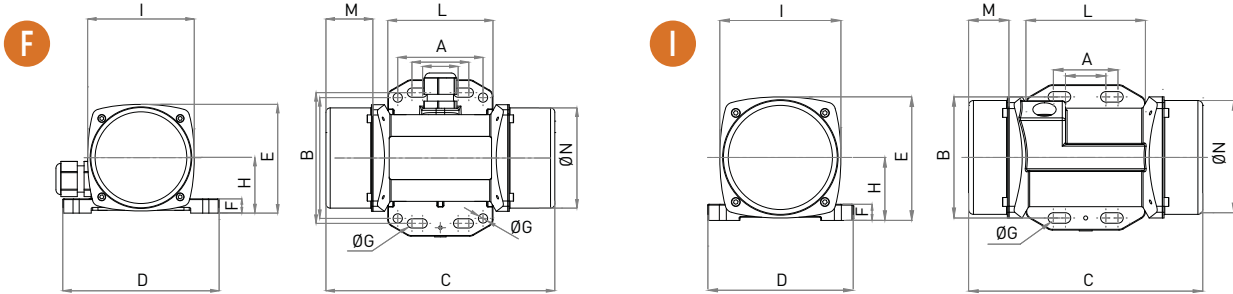

Model		Drawing	DIMENSIONAL SPECIFICATIONS (mm)												
			C	M	A	B	Ø G	Holes	D	E	F	H	I	L	N
50Hz	60Hz		50Hz	50Hz			N°								
MICRO 21/3		F	145	25	Multiple Footprint			4	110	76	10	39	75	74	70
					25-40	92	6.5								
MICRO 41/3		F	161	33	Multiple Footprint			4	110	76	10	39	75	74	70
					25-40	92	6.5								

Motor Name		Drawing	DIMENSIONAL SPECIFICATIONS (mm)												
			C	M	A	B	Ø G	Holes	D	E	F	H	I	L	N
50Hz	60Hz		50Hz	50Hz			N°								
MICRO 3/3 M		F	145	25	Multiple Footprint			4	110	76	10	39	75	74	70
					25-40	92	6.5								
MICRO 6/3 M		I	145	25	Multiple Footprint			4	90	76	10	39	75	74	70
					25-40	75	6.5								
MICRO 21/3 M		F	145	25	Multiple Footprint			4	110	76	10	39	75	74	70
					25-40	92	6.5								
MICRO 41/3 M		F	161	25	Multiple Footprint			4	110	76	10	39	75	74	70
					25-40	92	6.5								

NOTE: Dimensions with coarse degree of accuracy related to UNI 22768/1

This information is provided without warranty, representation, inducement or licence of any kind. It is accurate to the best OLI knowledge or is obtained from sources believed to be accurate. OLI therefore assumes no legal responsibility.

STANDARD
EXPLOSION-PROOF
INCREASED SAFETY
HI-STROKE MILLING



» I13 D Ex tD A22 Tx IP66
 » TÜV NORD Statement Conformity Number TÜV 05 ATEX 2768X
 » Equipment and protective system intended for use in potentially explosive atmospheres (Zone 22) - Directive 94/9/EC
 » Compliance with Essential Health and Safety Requirements
 » IEC 60079-10-2



MVE STANDARD RANGE



DC DIRECT CURRENT – 3000 rpm



* Image referred to size 23

Wm (kgcm)	Model	rpm	Centrifugal Force (kg)	Weight (kg)	ELECTRICAL SPECIFICATIONS			CERTIFICATE
					Input Power (kW)	Nominal Current A max	Cable Gland	 I13D
1	MVE 50 DC 12	3000	50	4.4	0.1	6.6	M16	100 °C
1	MVE 50 DC 24	3000	50	4.4	0.2	3.3	M16	100 °C
2	MVE 120 DC 12	3000	117	7.2	0.1	9.6	M20	100 °C
2	MVE 120 DC 24	3000	117	7.2	0.1	4.8	M20	100 °C
4	MVE 202 DC 12	3000	200	7.2	0.2	13.3	M20	100 °C
4	MVE 202 DC 24	3000	200	7.2	0.2	6.7	M20	100 °C
10	MVE 500 DC 24	3000	530	15.8	0.3	11.0	M20	100 °C
22	MVE 1500 DC 24	3000	1.616	21.6	0.5	21.5	M20	100 °C



» Declaration of conformity "type B" according to:
2006/95/EC - 2004/108/EC - 2006/42/EC - EN 60034-1

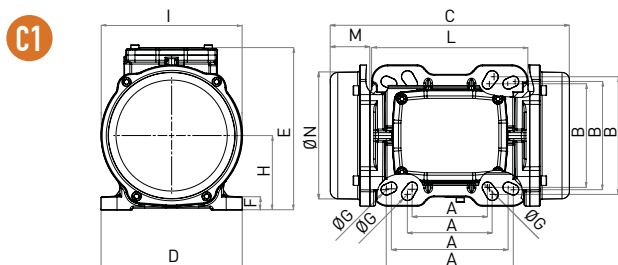
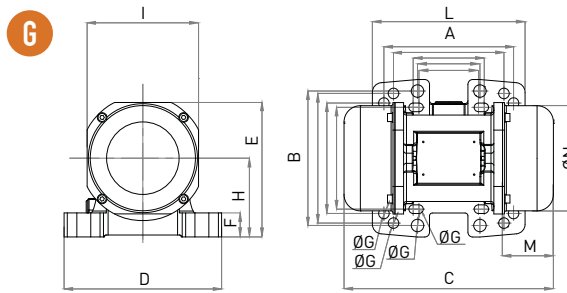
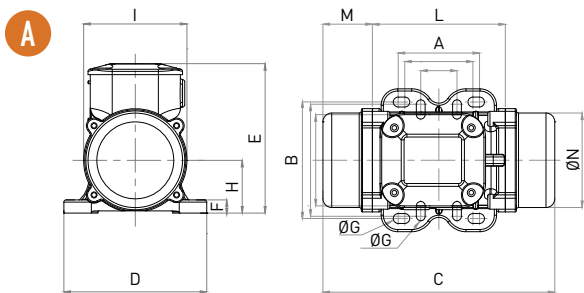

		DIMENSIONAL SPECIFICATIONS (mm)														
Model	Drawing	Size	C	M	A	B	ØG	Holes	D	E	F	H	I	L	N	
								N°								
MVE 50 DC 12	A	10	211	45	Multiple Footprint		4	130	136	12	48	94	121	85		
				62-74	106	9										
MVE 50 DC 24	A	10	211	45	33	83-102	7	4	130	136	12	48	94	121	85	
MVE 120 DC 12	G	23	218	53	Multiple Footprint		4	164	140	25	82	116	159	110		
				62-74	106	9										
MVE 120 DC 24	G	23	218	53	65	140	13	4	164	140	25	82	116	159	110	
MVE 202 DC 12	G	23	218	53	115	135	11	4	164	140	25	82	116	159	110	
MVE 202 DC 24	G	23	218	53	135	115	11	4	164	140	25	82	116	159	110	
MVE 500 DC 24	C1	40	330	78	105	140	13	4	170	195	15	92	174	174	160	
MVE 1500 DC 24	C1	50	321	62	120	170	18	4	208	209	18	96	184	198	169	

NOTE: Dimensions with coarse degree of accuracy related to UNI 22768/1

This information is provided without warranty, representation, inducement or licence of any kind. It is accurate to the best OLI knowledge or is obtained from sources believed to be accurate. OLI therefore assumes no legal responsibility.

STANDARD

INCREASED SAFETY

EXPLOSION-PROOF

HI-STROKE MILLING



MVE-E INCREASED SAFETY



2 POLES - 3000/3600 rpm



* Image referred to size 60

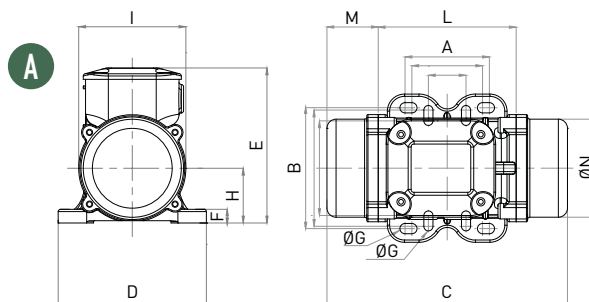

Wm (kgcm)		Model		Centrifugal Force (kg)		Weight (kg)		ELECTRICAL SPECIFICATIONS							CERTIFICATE	
50Hz	60Hz	50Hz	60Hz	50Hz	60Hz	50Hz	60Hz	Input Power (kW)		Nominal Current A max. (Y)		Ia / In		Cable Gland	Temp. Class	
50Hz	60Hz	50Hz	60Hz	50Hz	60Hz	50Hz	60Hz	50Hz	60Hz	50Hz (400V)	60Hz (460V)	50Hz	60Hz	Metric	GAS	DUST
4	3	MVE 200/3E	MVE 200/36E	187	189	7	7	0.2	0.2	0.3	0.3	3.3	3.3	M20	T3	150 °C
4	3	MVE 202/3E	MVE 202/36E	187	189	7	7	0.2	0.2	0.3	0.3	3.3	3.3	M20	T3	150 °C
6	4	MVE 300/3E	MVE 300/36E	321	323	10	10	0.3	0.3	0.5	0.4	3.6	3.5	M20	T3	150 °C
8	6	MVE 400/3E	MVE 400/36E	407	411	10	10	0.3	0.4	0.6	0.6	3.5	3.5	M20	T3	150 °C
10	7	MVE 500/3E	MVE 500/36E	530	534	16	16	0.5	0.6	1.0	1.0	4.0	4.2	M20	T3	150 °C
15	11	MVE 700/3E	MVE 700/36E	758	765	16	16	0.7	0.7	1.2	1.2	4.3	5.0	M20	T3	150 °C
16	11	MVE 800/3E	MVE 800/36E	794	800	21	21	0.7	0.9	1.4	1.5	3.8	3.8	M20	T3	150 °C
22	16	MVE 1200/3E	MVE 1200/36E	1,005	1,013	22	22	0.9	1.1	1.8	1.9	4.4	4.5	M20	T3	150 °C
20	14	MVE 1300/3E	MVE 1300/36E	1,355	1,365	22	22	1.3	1.4	2.4	2.2	5.2	5.0	M20	T3	150 °C
27	19	MVE 1301/3E	MVE 1301/36E	1,355	1,365	34	34	1.3	1.4	2.4	2.2	5.2	5.0	M20	T3	150 °C
27	19	MVE 1310/3E	MVE 1310/36E	1,123	1,616	34	34	1.3	1.4	2.4	2.2	5.2	5.0	M20	T3	150 °C
31	22	MVE 1600/3E	MVE 1600/36E	1,601	1,608	52	51	1.6	1.6	2.9	2.6	5.9	6.2	M25	T3	150 °C
37	28	MVE 2000/3E	MVE 2000/36E	2,027	1,997	53	52	2.0	2.1	3.7	3.4	6.5	6.4	M25	T3	150 °C
46	32	MVE 2300/3E	MVE 2300/36E	2,302	2,306	54	52	2.4	2.4	4.4	3.9	6.0	6.3	M25	T3	150 °C
68	44	MVE 3200/3E	MVE 3200/36E	3,252	3,176	103	101	2.9	2.9	5.3	4.6	8.3	8.2	M32	T3	150 °C
79	56	MVE 4000/3E	MVE 4000/36E	4,033	4,052	107	104	2.9	2.9	5.3	4.6	8.5	9.7	M32	T3	150 °C



» Declaration of conformity "type B" according to:
2006/95/EC - 2004/108/EC - 2006/42/EC - EN 60034-1



» IECEx BAS 06.0068X/2
» Cert. n. Baseefa 06ATEX0281X/2

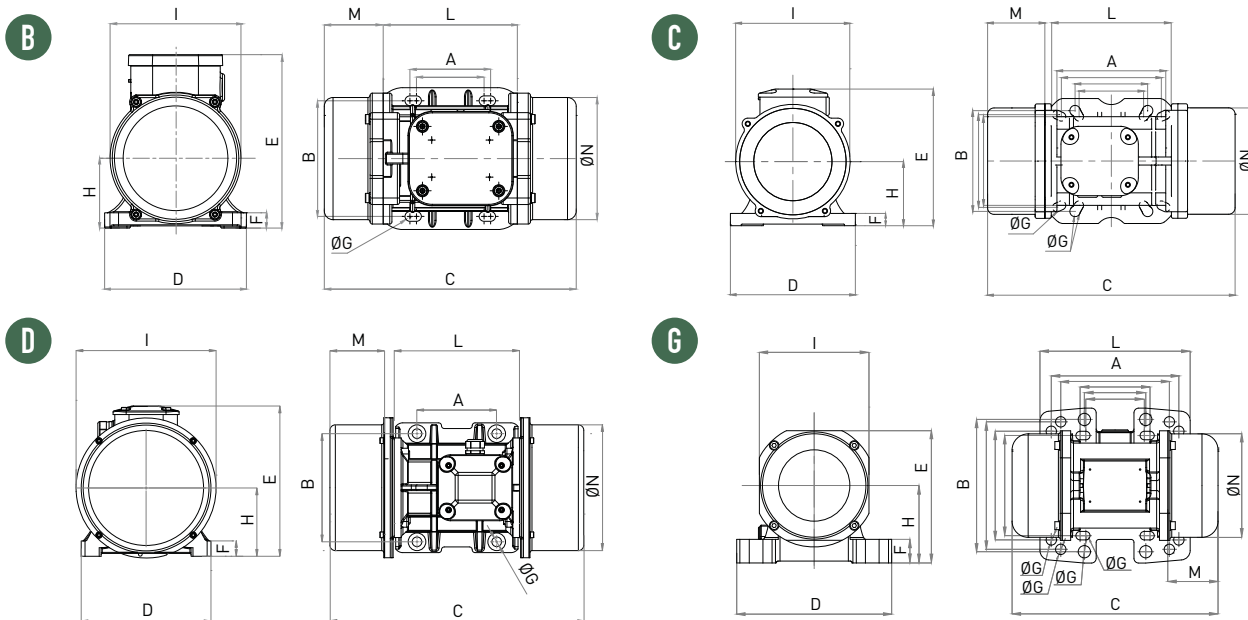

STANDARD

INCREASED SAFETY

EXPLOSION-PROOF

HI-STROKE MILLING

Model		Drawing	Size	DIMENSIONAL SPECIFICATIONS (mm)													
50Hz	60Hz			C		M		A	B	Ø G	Holes	D	E	F	H	I	L
				50Hz	60Hz	50Hz	60Hz				N°						
MVE 200/3E	MVE 200/36E	B	20	231	54	62-74	106	9	4	131	159	15	64	121	123	112	
MVE 202/3E	MVE 202/36E	G	23	218	53	Multiple Footprint			4	164	140	25	82	116	159	110	
						62-74	106	9									
						65	140	13									
						115	135	11									
MVE 300/3E	MVE 300/36E	C	30	253	45	Multiple Footprint			4	154	175	15	79	142	163	131	
						80	110	11									
MVE 400/3E	MVE 400/36E	C	30	273	55	Multiple Footprint			4	154	175	15	79	142	163	131	
						90	125	13									
						124	110	11									
				135	115	11											
MVE 500/3E	MVE 500/36E	D	40	334	78	105	140	13	4	168	196	22	92	169	178	158	
MVE 700/3E	MVE 700/36E	D	40	334	78	105	140	13	4	168	196	22	92	169	178	158	
MVE 800/3E	MVE 800/36E	D	50	321	58	120	170	17	4	208	210	22	94	180	205	170	
MVE 1200/3E	MVE 1200/36E	D	50	321	58	120	170	17	4	208	210	22	94	180	205	170	
MVE 1300/3E	MVE 1300/36E	D	50	321	58	120	170	17	4	208	210	22	94	180	205	170	
MVE 1301/3E	MVE 1301/36E	D	53	321	58	100	180	17	4	236	210	26	98	180	205	170	
MVE 1310/3E	MVE 1310/36E	D	55	321	58	100	200	17	4	236	210	26	98	180	205	170	
MVE 1600/3E	MVE 1600/36E	D	60	418	83	140	190	17	4	229	262	30	120	247	220	222	
MVE 2000/3E	MVE 2000/36E	D	60	418	83	140	190	17	4	229	262	30	120	247	220	222	
MVE 2300/3E	MVE 2300/36E	D	60	418	83	140	190	17	4	229	262	30	120	247	220	222	
MVE 3200/3E	MVE 3200/36E	D	75	538	115	155	255	25	4	302	318	35	147	295	273	264	
MVE 4000/3E	MVE 4000/36E	D	75	538	115	155	255	25	4	302	318	35	147	295	273	264	



MVE-E INCREASED SAFETY



4 POLES - 1500/1800 rpm



* Image referred to size 78

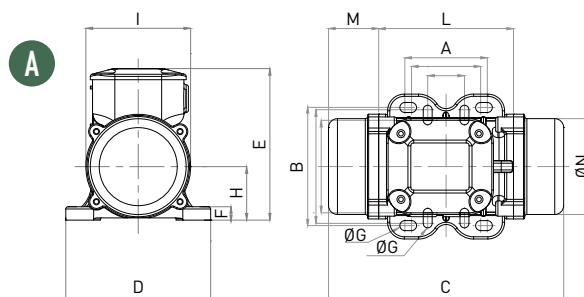

Wm (kgcm)		Model		Centrifugal Force (kg)		Weight (kg)		ELECTRICAL SPECIFICATIONS							CERTIFICATE	
50Hz	60Hz	50Hz	60Hz	50Hz	60Hz	50Hz	60Hz	Input Power (kW)		Nominal Current A max. (Y)		Ia / In		Cable Gland	Temp. Class	
50Hz	60Hz	50Hz	60Hz	50Hz	60Hz	50Hz	60Hz	50Hz	60Hz	50Hz (400V)	60Hz (460V)	50Hz	60Hz	Metric	GAS	DUST
15	11	MVE 200/15E	MVE 200/18E	194	196	12		0.2	0.2	0.5	0.5	2.0	2.0	M20	T3	150 °C
33	23	MVE 400/15E	MVE 400/18E	420	423	19		0.3	0.3	0.8	0.9	2.5	2.5	M20	T3	150 °C
40	28	MVE 500/15E	MVE 500/18E	504	508	21		0.3	0.4	1.1	1.1	2.8	2.7	M20	T3	150 °C
27	19	MVE 300/15E	MVE 300/18E	334	336	22		0.6	0.7	1.3	1.4	3.0	3.2	M20	T3	150 °C
57	39	MVE 700/15E	MVE 700/18E	714	712	27		0.6	0.7	1.3	1.4	3.0	3.2	M20	T3	150 °C
89	62	MVE 1100/15E	MVE 1100/18E	1,114	1,122	36	28	0.6	0.8	1.5	1.7	3.8	3.8	M20	T3	150 °C
108	77	MVE 1400/15E	MVE 1400/18E	1,364	1,388	60	58	0.9	1.1	1.7	1.8	4.0	4.0	M25	T3	150 °C
137	92	MVE 1700/15E	MVE 1700/18E	1,725	1,664	62	59	1.1	1.3	2.2	2.1	4.7	4.5	M25	T3	150 °C
188	137	MVE 2400/15E	MVE 2400/18E	2,358	2,485	68	62	1.6	1.9	3.0	3.2	4.9	4.9	M25	T3	150 °C
203	136	MVE 2500/15E	MVE 2500/18E	2,557	2,454	90	84	1.8	2.0	3.4	3.4	6.0	6.1	M25	T3	150 °C
249	170	MVE 3000/15E	MVE 3000/18E	3,124	3,071	97	87	1.9	2.3	3.7	3.8	6.5	6.6	M25	T3	150 °C
307	205	MVE 3800/15E	MVE 3800/18E	3,853	3,704	130	118	2.2	2.6	4.1	4.1	6.8	6.8	M32	T3	150 °C
343	241	MVE 4300/15E	MVE 4300/18E	4,312	4,359	134	124	2.5	3.0	5.7	5.8	7.0	7.2	M32	T3	150 °C
437	304	MVE 5500/15E	MVE 5500/18E	5,495	5,495	192	190	3.6	3.4	6.5	6.6	7.1	7.0	M32	T3	150 °C
								A max. (Δ)								
577	397	MVE 7200/15E	MVE 7200/18E	7,246	7,188	253	247	5.0	6.0	9.6	9.4	6.8	6.9	M32	T3	150 °C
718	499	MVE 9000/15E	MVE 9000/18E	9,020	9,023	269	258	7.5	8.5	12.0	12.0	7.0	7.0	M32	T3	150 °C
800	588	MVE 10000/15E	MVE 10000/18E	10,052	10,643	312	297	7.8	9.4	13.0	13.0	6.5	6.4	M32	T3	150 °C
939	655	MVE 11500/15E	MVE 11500/18E	11,779	11,853	445	422	9.0	10.5	15.5	15.5	7.0	7.0	M32	-	150 °C
1,142	838	MVE 14500/15E	MVE 14500/18E	14,352	15,153	460	442	11.5	13.0	18.5	18.5	8.0	8.0	M32	-	150 °C



» Declaration of conformity "type B" according to:
2006/95/EC - 2004/108/EC - 2006/42/EC - EN 60034-1



» IECEx BAS 06.0068X/2
» Cert. n. Baseefa 06ATEX0281X/2

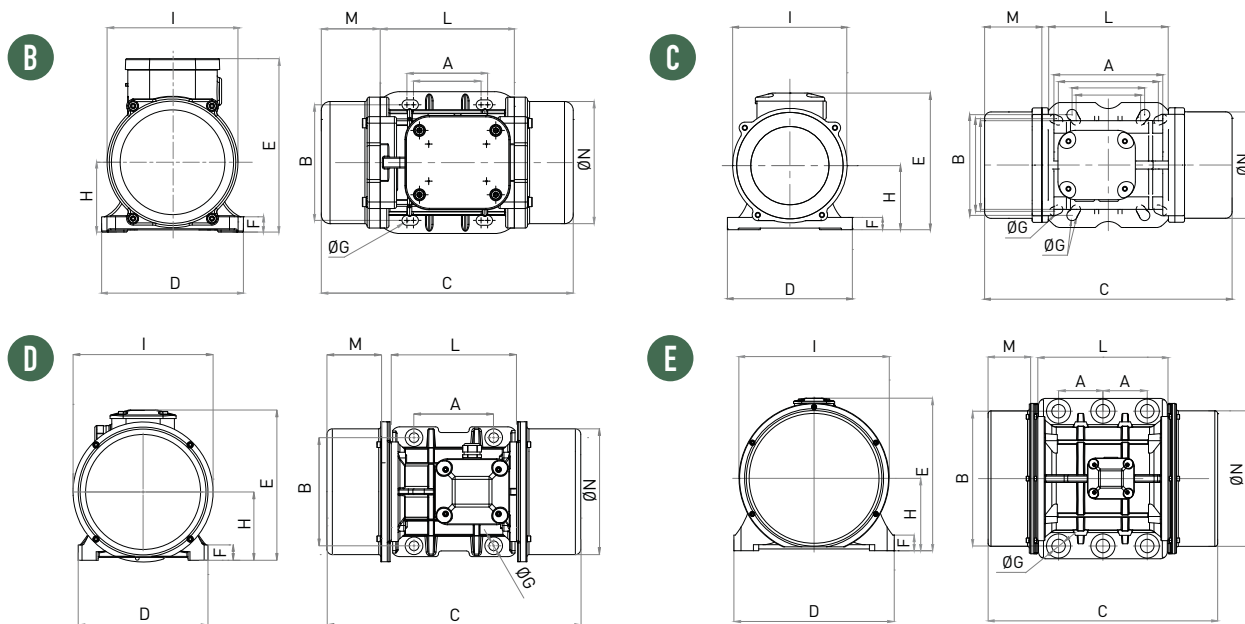

Model		Drawing	Size	DIMENSIONAL SPECIFICATIONS (mm)														
50Hz	60Hz			C		M		A	B	ØG	Holes	D	E	F	H	I	L	N
				50Hz	60Hz	50Hz	60Hz				N°							
MVE 200/15	MVE 200/18	C	30	273		55		Multiple Footprint			4	154	175	15	79	142	163	131
							80	110	11									
							90	125	13									
							124	110	11									
							135	115	11									
MVE 400/15E	MVE 400/18E	D	40	334		78		105	140	13	4	168	196	22	92	169	178	158
MVE 500/15E	MVE 500/18E	D	40	334		78		105	140	13	4	168	196	22	92	169	178	158
MVE 300/15E	MVE 300/18E	D	50	321		58		120	170	17	4	208	210	22	94	180	205	170
MVE 700/15E	MVE 700/18E	D	50	391		93		120	170	17	4	208	210	22	94	180	205	170
MVE 1100/15E	MVE 1100/18E	D	50	451	391	123	93	120	170	17	4	208	210	22	94	180	205	170
MVE 1400/15E	MVE 1400/18E	D	60	446		96		140	190	17	4	229	262	30	120	247	220	222
MVE 1700/15E	MVE 1700/18E	D	60	446		96		140	190	17	4	229	262	30	120	247	220	222
MVE 2400/15	MVE 2400/18E	D	60	510	446	129	96	140	190	17	4	229	262	30	120	247	220	222
MVE 2500/15E	MVE 2500/18E	D	70	522	486	123	105	155	225	22	4	272	295	40	140	267	250	235
MVE 3000/15E	MVE 3000/18E	D	70	556	486	123	105	155	225	22	4	272	295	40	140	267	250	235
MVE 3800/15E	MVE 3800/18E	D	75	588	538	140	115	155	255	23.5	4	302	318	35	147	295	273	264
MVE 4300/15E	MVE 4300/18E	D	75	588		140		155	255	23.5	4	302	318	35	147	295	273	264
MVE 5500/15E	MVE 5500/18E	D	80	603		130		180	280	26	4	332	360	37	167	345	304	310
MVE 7200/15E	MVE 7200/18E	D	85	608		120		200	320	28	4	378	411	49	200	424	325	378
MVE 9000/15E	MVE 9000/18E	D	85	608		120		200	320	28	4	378	411	49	200	424	325	378
MVE 10000/15E	MVE 10000/18E	E	90	726	646	160	120	125	380	39	6	452	430	44	204	422	367	378
MVE 11500/15E	MVE 11500/18E	E	100	890		210		140	440	45	6	530	484	37	232	446	470	424
MVE 14500/15E	MVE 14500/18E	E	100	890		210		140	440	45	6	530	484	37	232	446	470	424

STANDARD

INCREASED SAFETY

EXPLOSION-PROOF

HI-STROKE MILLING



MVE-E INCREASED SAFETY



6 POLES - 1000/1200 rpm



*1



*2

*1 Image referred to size 75

*2 Image referred to size 85

Wm (kgcm)		Model		Centrifugal Force (kg)		Weight (kg)		ELECTRICAL SPECIFICATIONS							CERTIFICATE		
50Hz	60Hz	50Hz	60Hz	50Hz	60Hz	50Hz	60Hz	Input Power (kW)		Nominal Current A max. (Y)		Ia / In		Cable Gland	Temp. Class		
50Hz	60Hz	50Hz	60Hz	50Hz	60Hz	50Hz	60Hz	50Hz	60Hz	50Hz (400V)	60Hz (460V)	50Hz	60Hz	Metric	GAS	DUST	
9	7	MVE 50/1E	MVE 50/12E	53	53	10		0.1	0.1	0.4	0.5	2.0	2.0	M20	T3	150 °C	
19	13	MVE 100/1E	MVE 100/12E	105	106	1		0.1	0.1	0.4	0.5	2.0	2.0	M20	T3	150 °C	
33	23	MVE 200/1E	MVE 200/12E	187	188	20		0.2	0.2	0.5	0.5	2.0	2.0	M20	T3	150 °C	
57	40	MVE 300/1E	MVE 300/12E	318	320	27		0.3	0.4	0.7	0.6	2.5	2.5	M20	T3	150 °C	
92	64	MVE 500/1E	MVE 500/12E	513	517	34		0.3	0.4	1.2	1.1	2.8	2.7	M20	T3	150 °C	
92	92	MVE 510/1E	MVE 510/12E	513	739	34		0.3	0.4	1.2	1.1	2.8	2.7	M20	T3	150 °C	
137	109	MVE 800/1E	MVE 800/12E	767	873	62	59	0.7	0.8	1.4	1.3	3.2	3.1	M25	T3	150 °C	
188	137	MVE 1100/1E	MVE 1100/12E	1,048	1,104	79	73	0.7	0.8	1.4	1.3	3.2	3.1	M25	T3	150 °C	
285	196	MVE 1500/1E	MVE 1500/12E	1,590	1,580	84	76	1.1	1.3	2.1	2.0	3.3	3.3	M25	T3	150 °C	
300	203	MVE 1600/1E	MVE 1600/12E	1,673	1,636	100	89	1.1	1.3	2.8	3.2	3.7	3.6	M25	T3	150 °C	
373	249	MVE 2100/1E	MVE 2100/12E	2,083	2,000	114	100	1.5	1.8	3.0	3.0	4.3	4.4	M25	T3	150 °C	
467	307	MVE 2600/1E	MVE 2600/12E	2,610	2,466	147	131	2.0	2.1	3.6	3.4	4.8	4.8	M32	T3	150 °C	
540	380	MVE 3000/1E	MVE 3000/12E	3,017	3,053	155	138	2.2	2.4	4.5	4.3	5.0	5.0	M32	T3	150 °C	
940	658	MVE 5210/1E	MVE 5210/12E	5,237	5,290	225	191	3.8	4.0	6.9	6.4	5.5	5.5	M25	T3	150 °C	
680	437	MVE 3800/1E	MVE 3800/12E	3,799	3,517	216	195	2.5	3.0	4.7	4.9	5.9	6.0	M32	T3	150 °C	
838	584	MVE 4700/1E	MVE 4700/12E	4,681	4,697	231	212	3.2	3.9	6.5	6.0	5.5	5.7	M32	T3	150 °C	
930	655	MVE 5200/1E	MVE 5200/12E	5,192	5,263	280	264	3.8	4.0	6.9	6.4	5.5	5.5	M32	T3	150 °C	
1,165	824	MVE 6500/1E	MVE 6500/12E	6,506	6,625	304	281	4.3	5.0	7.8	7.8	6.2	6.0	M32	T3	150 °C	
										A max. (Δ)							
1,436	930	MVE 8000/1E	MVE 8000/12E	8,018	7,476	325	290	7.1	7.5	12.6	11.6	6.0	6.2	M32	T3	150 °C	
1,600	1,165	MVE 9000/1E	MVE 9000/12E	8,936	9,369	338	308	7.5	8.3	13.2	12.6	6.3	6.2	M32	T3	150 °C	
1,788	1,240	MVE 10000/1E	MVE 10000/12E	9,986	9,970	386	359	7.6	8.0	13.5	12.7	6.4	6.4	M32	T3	150 °C	
2,330	-	MVE 13000/1E	NA	13,009	-	422	-	10.0	-	17.0	-	6.2	-	M32	T3	150 °C	



» Declaration of conformity "type B" according to:
2006/95/EC - 2004/108/EC - 2006/42/EC - EN 60034-1



» IECEx BAS 06.0068X/2
» Cert. n. Baseefa 06ATEX0281X/2

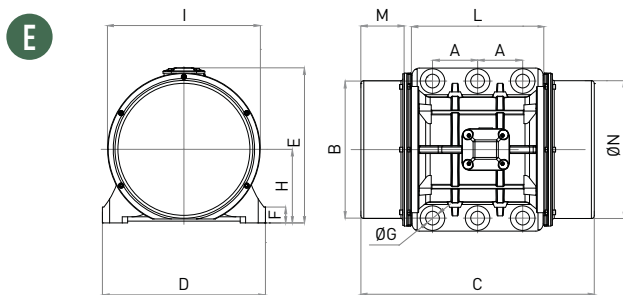
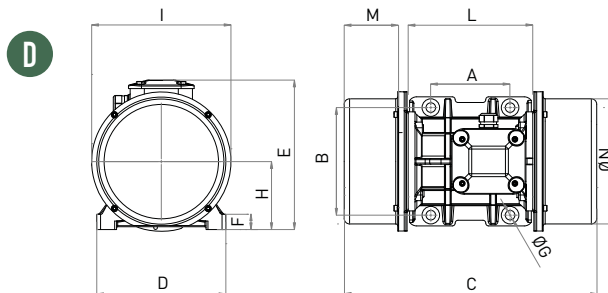
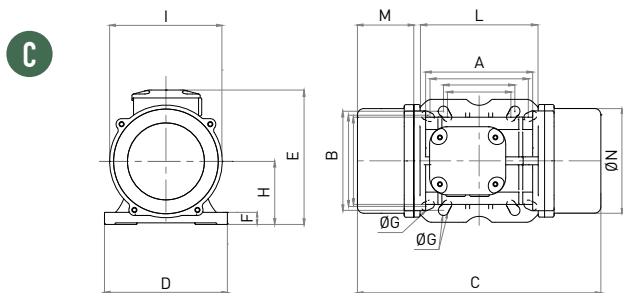

Model		Drawing	Size	DIMENSIONAL SPECIFICATIONS (mm)															
50Hz	60Hz			C		M		A	B	ØG	Holes	D	E	F	H	I	L	N	
				50Hz	60Hz	50Hz	60Hz				N°								
MVE 50/1E	MVE 50/12E	C	30	273		55		Multiple Footprint			4	154	175	15	79	142	163	131	
							80	110	11										
							90	125	13										
							124	110	11										
MVE 100/1E	MVE 100/12E	C	30	303		70		135 115 11			4	154	175	15	79	142	163	131	
MVE 200/1E	MVE 200/12E	D	40	334		78		105	140	13	4	168	196	22	92	169	178	158	
MVE 300/1E	MVE 300/12E	D	50	391		93		120	170	17	4	208	210	22	94	180	205	170	
MVE 500/1E	MVE 500/12E	D	50	451		123		120	170	17	4	208	210	22	94	180	205	170	
MVE 510/1E	MVE 510/12E	D	50	451		123		120	170	17	4	208	210	22	94	180	205	170	
MVE 800/1E	MVE 800/12E	D	60	446		96		140	190	17	4	229	262	30	120	247	220	222	
MVE 1100/1E	MVE 1100/12E	D	60	510	446	129	96	140	190	17	4	229	262	30	120	247	220	222	
MVE 1500/1E	MVE 1500/12E	D	60	562	510	154	129	140	190	17	4	229	262	30	120	247	220	222	
MVE 1600/1E	MVE 1600/12E	D	70	556	522	140	123	155	225	22	4	272	295	40	140	267	250	235	
MVE 2100/1E	MVE 2100/12E	D	70	616	556	170	140	155	225	22	4	272	295	40	140	267	250	235	
MVE 2600/1E	MVE 2600/12E	D	75	708	588	200	140	155	255	23.5	4	302	318	35	147	295	273	264	
MVE 3000/1E	MVE 3000/12E	D	75	708	608	200	150	155	255	23.5	4	302	318	35	147	295	273	264	
MVE 5210/1E	MVE 5210/12E	E	78	794		242		105	248	22	6	300	335	30	163	305	310	284	
MVE 3800/1E	MVE 3800/12E	D	80	683	603	170	130	180	280	26	4	332	360	37	167	345	304	310	
MVE 4700/1E	MVE 4700/12E	D	80	733	683	195	170	180	280	26	4	332	360	37	167	345	304	310	
MVE 5200/1E	MVE 5200/12E	D	85	688	605	160	120	200	320	28	4	378	411	49	200	424	325	378	
MVE 6500/1E	MVE 6500/12E	D	85	688		160		200	320	28	4	378	411	49	200	424	325	378	
MVE 8000/1E	MVE 8000/12E	D	85	788	688	210	160	200	320	28	4	378	411	49	200	424	325	378	
MVE 9000/1E	MVE 9000/12E	D	85	788	688	210	160	200	320	39	4	378	411	49	200	424	325	378	
MVE 10000/1E	MVE 10000/12E	E	90	826		210		125	380	39	6	452	430	44	204	422	367	378	
MVE 13000/1	NA	E	90	926	-	260	-	125	380	39	6	452	430	44	204	422	367	378	

STANDARD

INCREASED SAFETY

EXPLOSION-PROOF

HI-STROKE MILLING



MVE-E INCREASED SAFETY



8 POLES - 750/900 rpm



* Image referred to size 90

Wm (kgcm)		Model		Centrifugal Force (kg)		Weight (kg)		ELECTRICAL SPECIFICATIONS							CERTIFICATE	
								Input Power (kW)		Nominal Current A max. (Y)		Ia / In		Cable Gland	Temp. Class	
50Hz	60Hz	50Hz	60Hz	50Hz	60Hz	50Hz	60Hz	50Hz (400V)	60Hz (460V)	50Hz	60Hz	Metric	GAS	DUST		
33		MVE 150/075E	MVE 150/090E	105	151	21		0.2	0.2	1.1	1.1	1.5	1.5	M20	T3	150 °C
57		MVE 250/075E	MVE 250/090E	179	257	29		0.3	0.4	1.1	1.1	1.7	1.7	M20	T3	150 °C
84		MVE 400/075E	MVE 400/090E	264	380	35		0.3	0.4	1.1	1.1	1.9	1.9	M20	T3	150 °C
137		MVE 650/075E	MVE 650/090E	431	621	65		0.5	0.6	1.2	1.2	2.2	2.2	M25	T3	150 °C
188		MVE 900/075E	MVE 900/090E	589	849	71		0.6	0.8	1.2	1.3	2.5	2.5	M25	T3	150 °C
300		MVE 1300/075E	MVE 1300/090E	941	1,355	100		1.2	1.1	2.5	1.8	3.0	3.0	M25	T3	150 °C
467		MVE 2100/075E	MVE 2100/090E	1,468	2,114	150		1.5	1.8	2.8	2.9	4.2	4.1	M32	T3	150 °C
680		MVE 3100/075E	MVE 3100/090E	2,137	3,077	212		2.0	2.3	3.8	3.8	4.0	4.0	M32	T3	150 °C
838		MVE 3800/075E	MVE 3800/090E	2,633	3,792	230		2.5	3.0	6.0	6.0	3.9	4.0	M32	T3	150 °C
930		MVE 4200/075E	MVE 4200/090E	2,920	4,205	284		2.9	3.4	6.5	6.5	3.8	3.7	M32	T3	150 °C
1,165		MVE 5300/075E	MVE 5300/090E	3,660	5,270	305		4.0	4.3	8.5	8.0	3.8	4.2	M32	T3	150 °C
1,436		MVE 6500/075E	MVE 6500/090E	4,510	6,494	324		5.0	5.9	10.0	10.0	3.6	4.0	M32	T3	150 °C
										A max. (Δ)						
2,200		MVE 10000/075E	MVE 10000/090E	6,911	9,952	422		6.8	7.5	13.50	12.5	3.5	4.2	M32	T3	150 °C



» Declaration of conformity "type B" according to:
2006/95/EC - 2004/108/EC - 2006/42/EC - EN 60034-1



» IECEx BAS 06.0068X/2
» Cert. n. Baseefa 06ATEX0281X/2

D

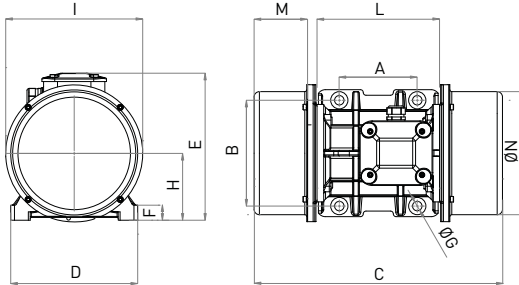

E

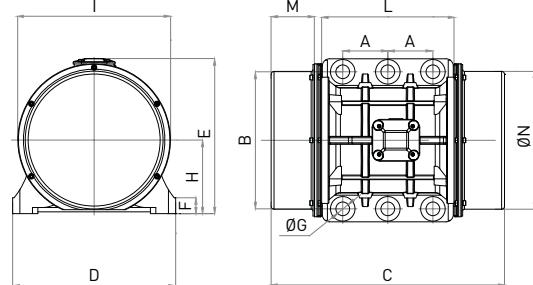

STANDARD

INCREASED SAFETY

EXPLOSION-PROOF

HI-STROKE MILLING

DIMENSIONAL SPECIFICATIONS (mm)

Model		Drawing	Size	C		M		A	B	Ø G	Holes N°	D	E	F	H	I	L	N
50Hz	60Hz			50Hz	60Hz													
MVE 150/075E	MVE 150/090E	D	40	334	78	105	140	13	4	168	196	22	92	169	178	158		
MVE 250/075E	MVE 250/090E	D	50	391	93	120	170	17	4	208	210	22	94	180	205	170		
MVE 400/075E	MVE 400/090E	D	50	451	123	120	170	17	4	208	210	22	94	180	205	170		
MVE 650/075E	MVE 650/090E	D	60	446	96	140	190	17	4	229	262	30	120	247	220	222		
MVE 900/075E	MVE 900/090E	D	60	510	129	140	190	17	4	229	262	30	120	247	220	222		
MVE 1300/075E	MVE 1300/090E	D	70	556	140	155	225	22	4	272	295	40	140	267	250	235		
MVE 2100/075E	MVE 2100/090E	D	75	708	200	155	255	23.5	4	302	318	35	147	295	273	264		
MVE 3100/075E	MVE 3100/090E	D	80	683	170	180	280	26	4	332	360	37	167	345	304	310		
MVE 3800/075E	MVE 3800/090E	D	80	733	195	180	280	26	4	332	360	37	167	345	304	310		
MVE 4200/075E	MVE 4200/090E	D	85	688	160	200	320	28	4	378	410	49	199	422	325	378		
MVE 5300/075E	MVE 5300/090E	D	85	688	160	200	320	28	4	378	410	49	199	422	325	378		
MVE 6500/075E	MVE 6500/090E	D	85	788	210	200	320	28	4	378	410	49	199	422	325	378		
MVE 10000/075E	MVE 10000/090E	E	90	926	260	125	380	39	6	452	430	44	204	422	367	378		





II 2G Ex d IIB T4 Ex tD A21 IP66 T135°C
 Ex d IIB T4 Gb
 Ex tD A21 IIIC T135°C Db IP66
 Class I Div.1 groups C, D Class II Div.1 groups E, F, G T4 IP66



II 2G Ex d IIB T3
 Ex d IIB T3 Gb
 Class I Div.1 groups C, D T3

MVE-D EXPLOSION-PROOF



* Image referred to size 78

2 POLES - 3000/3600 rpm

Wm (kgcm)		Model		Centrifugal Force (kg)		Weight (kg)		ELECTRICAL SPECIFICATIONS							
50Hz	60Hz	50Hz	60Hz	50Hz	60Hz	50Hz	60Hz	Input Power (kW)		Nominal Current A max. (Y)		Ia / In		Cable Gland	
50Hz	60Hz	50Hz	60Hz	50Hz	60Hz	50Hz	60Hz	50Hz	60Hz	50Hz (400V)	60Hz (460V)	50Hz	60Hz	Metric	
16	11	MVE 800/3D	MVE 800/36D	794	800	29		0.7	0.9	1.4	1.5	3.8	3.8	M20	
27	19	MVE 1300/3D	MVE 1300/36D	1,355	1,365	30		1.3	1.4	2.4	2.2	5.2	5.0	M20	
31	22	MVE 1600/3D	MVE 1600/36D	1,601	1,608	60	60	1.6	1.6	2.9	2.6	5.9	6.2	M25	
37	28	MVE 2000/3D	MVE 2000/36D	2,027	1,997	61	60	2.0	2.1	3.7	3.4	6.5	6.4	M25	
46	32	MVE 2300/3D	MVE 2300/36D	2,302	2,306	62	60	2.4	2.4	4.4	3.9	6.0	6.3	M25	
68	44	MVE 3200/3D	MVE 3200/36D	3,252	3,176	111	110	2.9	2.9	5.3	4.6	8.3	8.2	M32	
79	56	MVE 4000/3D	MVE 4000/36D	4,033	4,052	115	111	2.9	2.9	5.3	4.6	8.5	9.7	M32	

4 POLES - 1500/1800 rpm

Wm (kgcm)		Model		Centrifugal Force (kg)		Weight (kg)		ELECTRICAL SPECIFICATIONS							
50Hz	60Hz	50Hz	60Hz	50Hz	60Hz	50Hz	60Hz	Input Power (kW)		Nominal Current A max. (Y)		Ia / In		Cable Gland	
50Hz	60Hz	50Hz	60Hz	50Hz	60Hz	50Hz	60Hz	50Hz	60Hz	50Hz (400V)	60Hz (460V)	50Hz	60Hz	Metric	
57	39	MVE 700/15D	MVE 700/18D	714	712	36		0.6	0.7	1.3	1.4	3.0	3.2	3/4" NPT	
89	57	MVE 1100/15D	MVE 1100/18D	1,114	1,028	44	39	0.6	0.8	1.5	1.7	3.8	3.8		
109	77	MVE 1400/15D	MVE 1400/18D	1,364	1,388	68	67	0.9	1.1	1.7	1.8	4.0	4.0		
137	92	MVE 1700/15D	MVE 1700/18D	1,725	1,664	70	68	1.1	1.3	2.2	2.1	4.7	4.5		
187	137	MVE 2400/15D	MVE 2400/18D	2,358	2,485	76	70	1.6	1.9	3.0	3.2	4.9	4.9		
203	136	MVE 2500/15D	MVE 2500/18D	2,557	2,454	98	92	1.8	2.0	3.4	3.4	6.0	6.1		
249	170	MVE 3000/15D	MVE 3000/18D	3,124	3,071	106	95	1.9	2.3	3.7	3.8	6.5	6.6		
307	205	MVE 3800/15D	MVE 3800/18D	3,853	3,704	138	127	2.2	2.6	4.1	4.1	6.8	6.8		
307	205	MVE 3810/15D	MVE 3810/18D	3,853	3,704	140	129	2.2	2.6	4.1	4.1	6.8	6.8		
193	193	MVE 3811/15D	MVE 3811/18D	2,425	3,492	129	129	2.2	2.6	4.1	4.1	6.8	6.8		
343	241	MVE 4300/15D	MVE 4300/18D	4,312	4,359	143	132	2.5	3.0	5.7	5.8	7.0	7.2		
437	304	MVE 5500/15D	MVE 5500/18D	5,495	5,495	201	198	3.6	3.4	6.5	6.6	7.1	7.0		



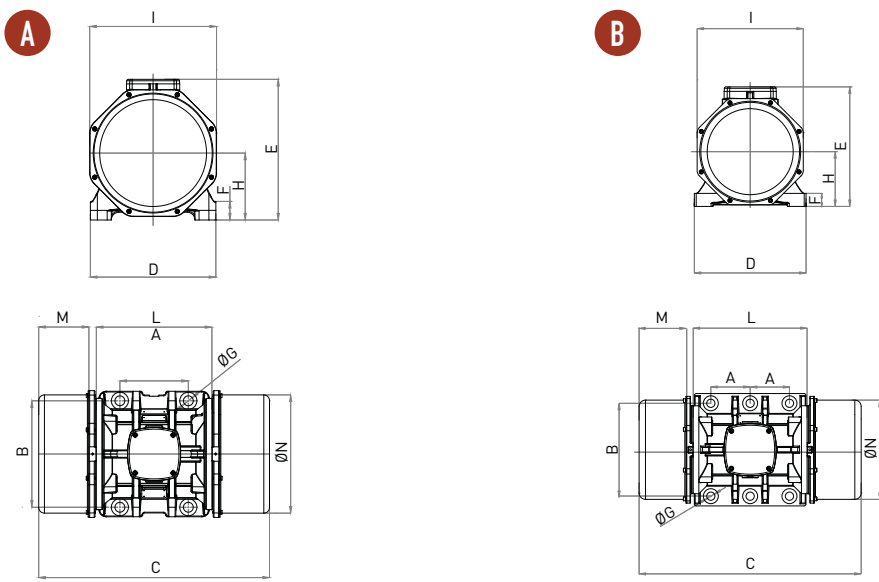

Model		Drawing	Size	DIMENSIONAL SPECIFICATIONS (mm)														
50Hz	60Hz			C		M		A	B	Ø G	Holes	D	E	F	H	I	L	N
				50Hz	60Hz	50Hz	60Hz				N°							
MVE 800/3D	MVE 800/36D	A	50	335		65		120	170	17	4	209	240	27.5	103	195	205	166.5
MVE 1300/3D	MVE 1300/36D	A	50	335		65		120	170	17	4	209	240	27.5	103	195	205	166.5
MVE 1600/3D	MVE 1600/36D	A	60	478		105		140	190	17	4	234	267	31	124	238	234	222
MVE 2000/3D	MVE 2000/36D	A	60	478		105		140	190	17	4	234	267	31	124	238	234	222
MVE 2300/3D	MVE 2300/36D	A	63	478		105		140	190	22	4	234	267	31	124	238	234	222
MVE 3200/3D	MVE 3200/36D	A	75	569		115		155	255	23.5	4	300	321	35	147	285	298	265
MVE 4000/3D	MVE 4000/36D	A	75	569		115		155	255	23.5	4	300	321	35	147	285	298	265

Model		Drawing	Size	DIMENSIONAL SPECIFICATIONS (mm)														
50Hz	60Hz			C		M		A	B	Ø G	Holes	D	E	F	H	I	L	N
				50Hz	60Hz	50Hz	60Hz				N°							
MVE 700/15D	MVE 700/18D	A	50	405		100		120	170	17	4	209	240	28	103	195	205	166.5
MVE 1100/15D	MVE 1100/18D	A	50	467	405	131	100	120	170	17	4	209	240	28	103	195	205	166.5
MVE 1400/15D	MVE 1400/18D	A	60	478		105		140	190	17	4	234	267	31	124	238	234	222
MVE 1700/15D	MVE 1700/18D	A	63	478		105		140	190	22	4	234	267	31	124	238	234	222
MVE 2400/15D	MVE 2400/18D	A	63	538		135		140	190	22	4	234	267	31	124	238	234	222
MVE 2500/15D	MVE 2500/18D	A	70	526		115		155	225	22	4	274	309	35	140	255	264	236
MVE 3000/15D	MVE 3000/18D	A	70	590		147		155	225	22	4	274	309	35	140	255	264	236
MVE 3800/15D	MVE 3800/18D	A	75	619		140		155	255	23.5	4	300	321	35	147	285	304	265
MVE 3810/15D	MVE 3810/18D	B	77	619		140		105	248	22	6	300	321	35	147	285	304	265
MVE 3811/15D	MVE 3811/18D	B	77	619		140		105	248	22	6	300	321	35	147	285	304	265
MVE 4300/15D	MVE 4300/18D	A	75	619		140		155	255	23.5	4	300	321	35	147	285	304	265
MVE 5500/15D	MVE 5500/18D	A	80	613		135		180	280	26	4	330	370	50	176	334	304	311

STANDARD

INCREASED SAFETY

EXPLOSION-PROOF

HI-STROKE MILLING



II 2GD Ex d IIB T4 Ex tD A21 IP66 T135°C
 Ex d IIB T4 Gb
 Ex tD A21 IIIC T135°C Db IP66
 Class I Div.1 groups C, D Class II Div.1 groups E, F, G T4 IP66



II 2G Ex d IIB T3
 Ex d IIB T3 Gb
 Class I Div.1 groups C, D T3

MVE-D EXPLOSION-PROOF



* Image referred to size 60

6 POLES - 1000/1200 rpm

Wm (kgcm)		Model		Centrifugal Force (kg)		Weight (kg)		ELECTRICAL SPECIFICATIONS							
50Hz	60Hz	50Hz	60Hz	50Hz	60Hz	50Hz	60Hz	Input Power (kW)		Nominal Current A max. (V)		Ia / In		Cable Gland	
50Hz	60Hz	50Hz	60Hz	50Hz	60Hz	50Hz	60Hz	50Hz	60Hz	50Hz (400V)	60Hz (460V)	50Hz	60Hz	Metric	
92		MVE 500/1D	MVE 500/12D	513	739		34	0.3	0.4	1.2	1.1	2.8	2.7	3/4" NPT	
137	109	MVE 800/1D	MVE 800/12D	767	873		70	0.7	0.8	1.4	1.3	3.2	3.1		
188	137	MVE 1100/1D	MVE 1100/12D	1,048	1,104	88	81	0.7	0.8	1.4	1.3	3.2	3.1		
285	197	MVE 1500/1D	MVE 1500/12D	1,590	1,580	92	85	1.1	1.3	2.1	2.0	3.3	3.3		
300	203	MVE 1600/1D	MVE 1600/12D	1,673	1,636	108	97	1.1	1.3	2.8	3.2	3.7	3.6		
373	249	MVE 2100/1D	MVE 2100/12D	2,083	2,000	123	109	1.5	1.8	3.0	3.0	4.3	4.4		
467	307	MVE 2600/1D	MVE 2600/12D	2,610	2,466	157	140	2.0	2.1	3.6	3.4	4.8	4.8		
540	380	MVE 3000/1D	MVE 3000/12D	3,017	3,053	164	146	2.2	2.4	4.5	4.3	5.0	5.0		
680	437	MVE 3800/1D	MVE 3800/12D	3,799	3,517	224	203	2.5	3.0	4.7	4.9	5.9	6.0		
838	584	MVE 4700/1D	MVE 4700/12D	4,681	4,697	239	221	3.2	3.9	6.5	6.0	5.5	5.7		

UP TO SIZE 60 (INCLUDED)
60Hz masses = 50Hz masses adjusted at 70%

ABOVE SIZE 60 (NOT INCLUDED)
Specific masses for 60Hz
Except for model MVE 1500/1D - 1500/12D

8 POLES - 750/900 rpm

Wm (kgcm)		Model		Centrifugal Force (kg)		Weight (kg)		ELECTRICAL SPECIFICATIONS							
50Hz	60Hz	50Hz	60Hz	50Hz	60Hz	50Hz	60Hz	Input Power (kW)		Nominal Current A max. (V)		Ia / In		Cable Gland	
50Hz	60Hz	50Hz	60Hz	50Hz	60Hz	50Hz	60Hz	50Hz	60Hz	50Hz (400V)	60Hz (460V)	50Hz	60Hz	Metric	
57		MVE 250/075D	MVE 250/090D	179	257		38	0.3	0.4	1.1	1.1	1.7	1.7	3/4" NPT	
84		MVE 400/075D	MVE 400/090D	264	380		43	0.3	0.4	1.1	1.1	1.9	1.9		
137		MVE 650/075D	MVE 650/090D	431	621		73	0.5	0.6	1.2	1.2	2.2	2.2		
188		MVE 900/075D	MVE 900/090D	589	849		79	0.6	0.8	1.2	1.3	2.5	2.5		
300		MVE 1300/075D	MVE 1300/090D	941	1,355		108	1.0	1.1	1.9	1.8	3.0	3.0		
467		MVE 2100/075D	MVE 2100/090D	1,468	2,114		159	1.5	1.8	2.8	2.9	4.2	4.1		
680		MVE 3100/075D	MVE 3100/090D	2,137	3,077		221	2.0	2.3	3.8	3.8	4.0	4.0		
838		MVE 3800/075D	MVE 3800/090D	2,633	3,792		239	2.5	3.0	6.0	6.0	3.9	4.0		



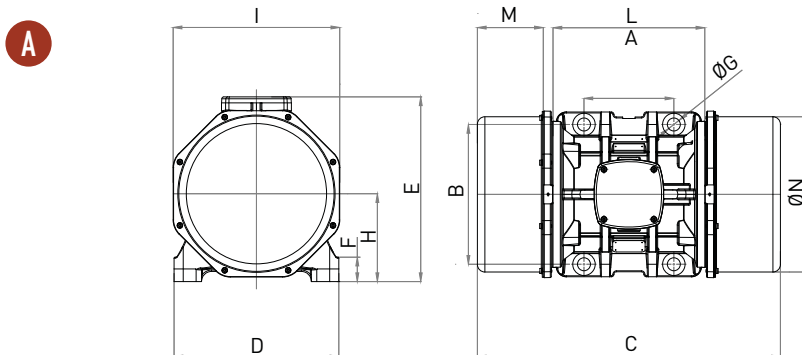

STANDARD
INCREASED SAFETY
EXPLOSION-PROOF
HI-STROKE MILLING

Model		Drawing	Size	DIMENSIONAL SPECIFICATIONS (mm)														
50Hz	60Hz			C		M		A	B	ØG	Holes	D	E	F	H	I	L	N
				50Hz	60Hz	50Hz	60Hz				N°							
MVE 500/1D	MVE 500/12D	A	50	467	131	120	170	17	4	209	240	28	103	195	205	166		
MVE 800/1D	MVE 800/12D	A	60	478	105	140	190	17	4	234	267	31	124	238	234	222		
MVE 1100/1D	MVE 1100/12D	A	63	538	135	140	190	22	4	234	267	31	124	238	234	222		
MVE 1500/1D	MVE 1500/12D	A	60	598	165	140	190	17	4	234	267	31	124	238	234	222		
MVE 1600/1D	MVE 1600/12D	A	70	590	147	155	225	22	4	274	309	35	140	255	264	236		
MVE 2100/1D	MVE 2100/12D	A	70	650	177	155	225	22	4	274	309	35	140	255	264	236		
MVE 2600/1D	MVE 2600/12D	A	75	739	200	155	255	23	4	300	321	35	147	285	304	265		
MVE 3000/1D	MVE 3000/12D	A	75	739	200	155	255	23	4	300	321	35	147	285	304	265		
MVE 3800/1D	MVE 3800/12D	A	80	693	175	180	280	26	4	330	370	50	176	334	304	311		
MVE 4700/1D	MVE 4700/12D	A	80	753	205	180	280	26	4	330	370	50	176	334	304	311		

Model		Drawing	Size	DIMENSIONAL SPECIFICATIONS (mm)														
50Hz	60Hz			C		M		A	B	ØG	Holes	D	E	F	H	I	L	N
				50Hz	60Hz	50Hz	60Hz				N°							
MVE 250/075D	MVE 250/090D	A	50	405	100	120	170	17	4	209	240	28	103	195	205	166		
MVE 400/075D	MVE 400/090D	A	50	467	131	120	170	17	4	209	240	28	103	195	205	166		
MVE 650/075D	MVE 650/090D	A	60	478	105	140	190	17	4	234	267	31	124	238	234	222		
MVE 900/075D	MVE 900/090D	A	63	538	135	140	190	17	4	234	267	31	124	238	234	222		
MVE 1300/075D	MVE 1300/090D	A	70	590	147	155	225	22	4	274	309	35	140	255	264	236		
MVE 2100/075D	MVE 2100/090D	A	75	739	200	155	255	23	4	300	321	35	147	285	304	265		
MVE 3100/075D	MVE 3100/090D	A	80	693	175	180	280	26	4	330	370	50	176	334	304	311		
MVE 3800/075D	MVE 3800/090D	A	80	753	205	180	280	26	4	330	370	50	176	334	304	311		



- » I13 D Ex tD A22 Tx IP66
- » TÜV NORD Statement Conformity Number TÜV 05 ATEX 2768X
- » Equipment and protective system intended for use in potentially explosive atmospheres [Zone 22] - Directive 94/9/EC
- » Compliance with Essential Health and Safety Requirements
- » IEC 60079-10-2



MVE HI-STROKE MILLING



8 POLES – 750 rpm

Wm (kgcm)		Model		Centrifugal Force (kg)		Weight (kg)		ELECTRICAL SPECIFICATIONS						CERTIFICATE
								Input Power (kW)		Nominal Current A max. (Y)		Ia / In		Cable Gland
50Hz	60Hz	50Hz	60Hz	50Hz	60Hz	50Hz	60Hz	50Hz	60Hz	50Hz	60Hz	Metric	Temp. Class	
383	-	MVE 1200/075	NA	1,203	-	94	0.6	-	1.3	-	2.5	-	M25	135 °C
471	-	MVE 1400/075	NA	1,480	-	104	0.6	-	1.5	-	2.5	-	M25	135 °C

10 POLES – 600/720 rpm

Wm (kgcm)		Model		Centrifugal Force (kg)		Weight (kg)		ELECTRICAL SPECIFICATIONS						CERTIFICATE
								Input Power (kW)		Nominal Current A max. (Δ)		Ia / In		Cable Gland
50Hz	60Hz	50Hz	60Hz	50Hz	60Hz	50Hz	60Hz	50Hz	60Hz	50Hz	60Hz	Metric	Temp. Class	
383		MVE 1200/060	MVE 1200/072	770	1,110	94	0.8	0.8	1.4	1.3	1.5	1.5	M25	100 °C
471		MVE 1400/060	MVE 1400/072	947	1,364	104	0.8	0.8	1.4	1.3	1.5	1.5	M25	100 °C



» Declaration of conformity "type B" according to:
2006/95/EC - 2004/108/EC - 2006/42/EC - EN 60034-1

L

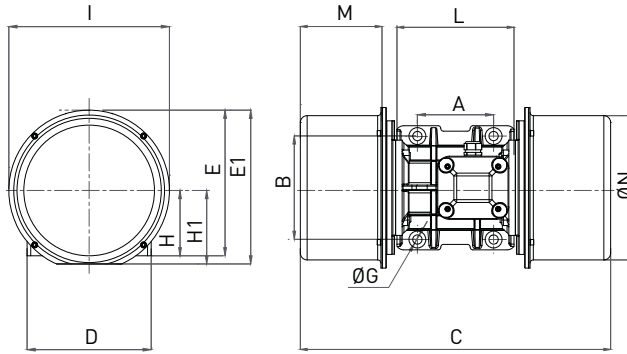

Model		Drawing	Size	DIMENSIONAL SPECIFICATIONS (mm)																
				C		M		A	B	ØG	Holes	D	E	E1	F	H	H1	I	L	N
50Hz	60Hz			50Hz	60Hz	50Hz	60Hz				N°									
MVE 1200/075	NA	L	60	570		150		140	190	17	4	228	268	283	23	120	135	295	220	265
MVE 1400/075	NA	L	60	570		140		140	190	17	4	228	268	283	23	120	135	295	220	265

Model		Drawing	Size	DIMENSIONAL SPECIFICATIONS (mm)																
				C		M		A	B	ØG	Holes	D	E	E1	F	H	H1	I	L	N
50Hz	60Hz			50Hz	60Hz	50Hz	60Hz				N°									
MVE 1200/060	MVE 1200/072	L	60	570		150		140	190	17	4	228	268	283	23	135	135	295	220	265
MVE 1400/060	MVE 1400/072	L	60	570		150		140	190	17	4	228	268	283	23	135	135	295	220	265

STANDARD

INCREASED SAFETY

EXPLOSION-PROOF

HI-STROKE MILLING





INSTALLATION

Mounting

The base plate surface where the vibrator motor is mounted has an allowable tolerance of 0.25mm (0.01in), so that the surfaces rest uniformly against each other to avoid internal tension that may cause breakage of the foot of the vibrator motor.

Use 8.8 type bolts, 8.0 type nuts and flat washers belonging to category A EN ISO 7089 / 7092.

The graph below show the correct torque settings for the different bolt sizes used on the motor vibrators.

Motor / Machine interface

Screw		Washer		Clamping torque	
Metric	Imperial	Metric UNI 6592	Imperial Flat washer	(Nm)	(ftlb)
M6	1/4"	6.4 x 12	1/4"	9	6.5
M8	5/16"	8.4 x 16	5/16"	23	16.5
M10	3/8"	10.5 x 20	3/8"	45	33
M12	1/2"	13 x 24	1/2"	80	58
M16	5/8"	17 x 30	5/8"	185	137
M20	13/16"	21 x 37	13/16"	373	275
M22	7/8"	23 x 39	7/8"	550	411
M24	15/16"	25 x 44	15/16"	696	513
M27	1"	28 x 50	1"	873	645
M36	1-3/8"	37 x 66	1-3/8"	1,864	1,370
M42	1 5/8"	37 x 66	1 5/8"	2,850	2,102

FIXING

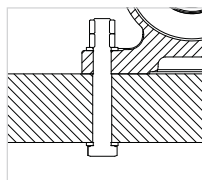

Smooth through borehole
+ screw
+ flat washer
+ nut and conternut

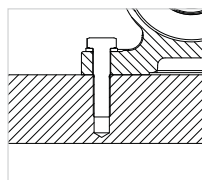

Tapped threaded borehole
+ screw
+ flat washer

SURFACE FLATNESS TOLERANCE

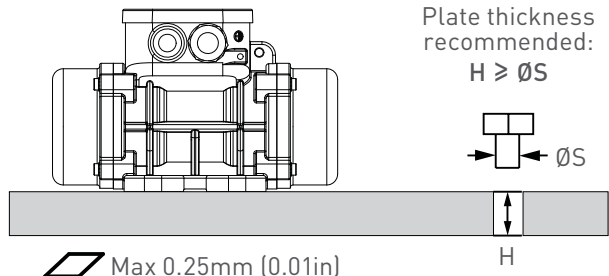

**MACHINED & NOT PAINTED
SUPPORT PLATE**



Electrical connection

Make sure the voltage and frequency supply match the ones indicated on the rating plate of the electric vibrator.

If the motor is operated via a variable frequency drive do not run it under 20 Hz and not over the rated frequency.

Insert the power cable through the cable gland. The lead-in wires have to be of the eyelet-type, pre-insulated, with a bore that suits the terminals of the junction box in order to prevent overheating of the wire. Use only conductors that have a suitable cross-section.

Connect the lead wires to the pins (as shown in the diagram below) and tighten them with the specified torque:

Do not forget to fix the earthing cable to the provided studs

→ **Compulsory connection!**

Before closing the junction box make sure the cover gasket is properly fitted in order to keep the specified IP protection.

For more details on motor installation refer to product manuals.

Junction box nuts tightening torque		
Screw	Nm	ftlb
M4	2.5	1.84
M5	4	2.95
M6	5	3.69
M8	6	4.43
M10	8	5.90

TERMINAL CONNECTIONS

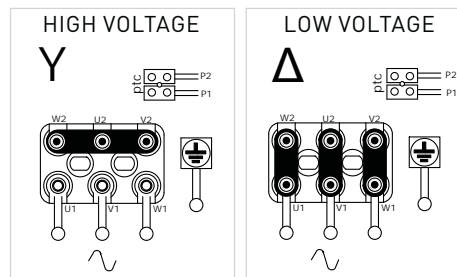

Check "Nominal Current" column label to know the factory preset connection of each motor.

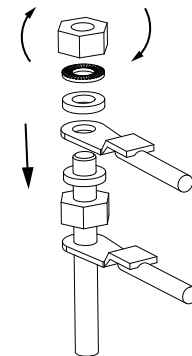

Overload protection

All electric vibrators **MUST** be connected to a suitable external overload protection.

When using two electric vibrators in sync, each of them has to be connected to an external overload protection that must be interlocked to make sure both motors are stopped if one fails.

Always use a thermal-magnetic type motor protection, with delayed cut-off, to avoid stopping

the motor during start-up when the current draw is higher than the rated running current for a few seconds.

Cut-off of the overload protection should be set at a maximum of +10% of the rated current.



HOW TO CHANGE THE VIBRATION INTENSITY

Adjustable masses - Type A

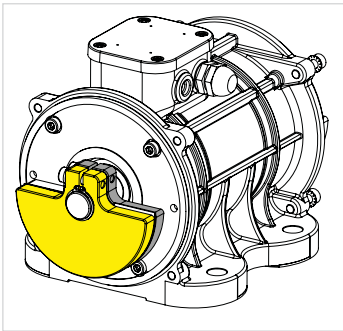

MASSES AT 100%

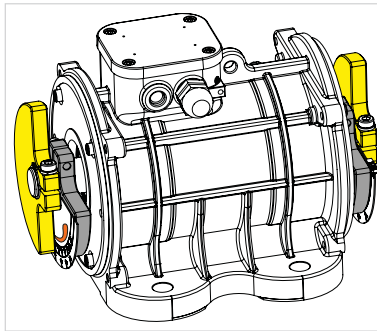

ADJUSTED MASSES

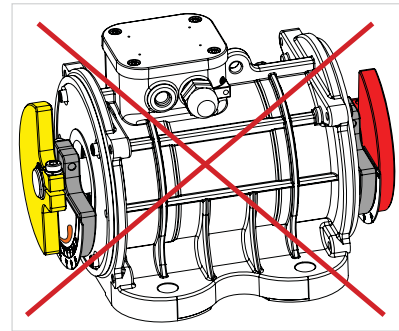

INCORRECTLY ADJUSTED MASSES

2 TIPS TO CORRECTLY ADJUST MASSES:

Rotate the mass following the design on the plate: from the thicker tip towards the thin tip.

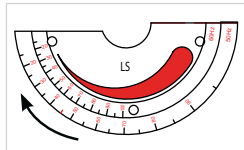

*left side of the motor,
for sizes up to 60*

Rotate the masses in the opposite direction to the cable gland.

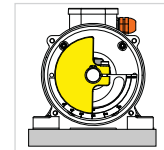

left side

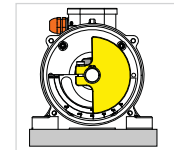

right side

Adjustable masses - Type B

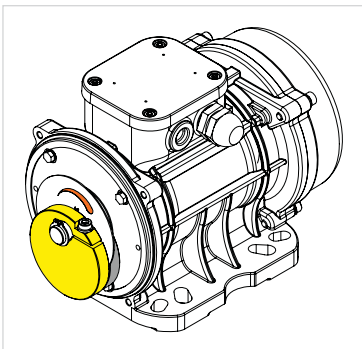

MASSES AT 100%

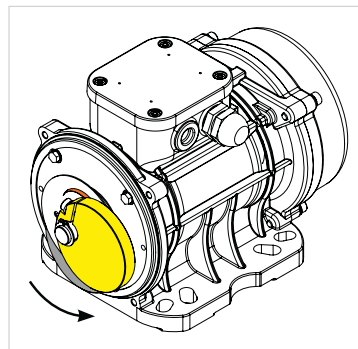

ADJUSTED MASSES

The fissure in the mass indicates the degree of adjustment.

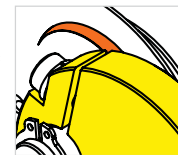

Rotate the mass following the design on the plate: from the thicker tip towards the thin tip.

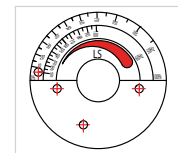



Adjustable masses - Type C (blade masses)

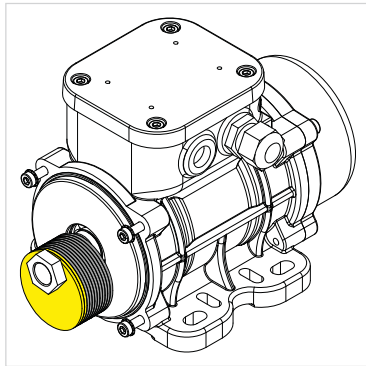

MASSES AT 100%

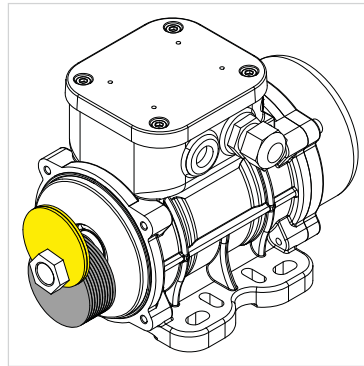

ADJUSTED MASSES

For technical information on the regulation of blade masses refer to the Use and Maintenance Manual.



Warning:
DO NOT grease new motors before installation.

OLI motors with roller bearings leave the factory filled with the right quantity of grease while those with ball bearing do not need any lubrication.